

# PRESSURE SEAL FORGED VALVES

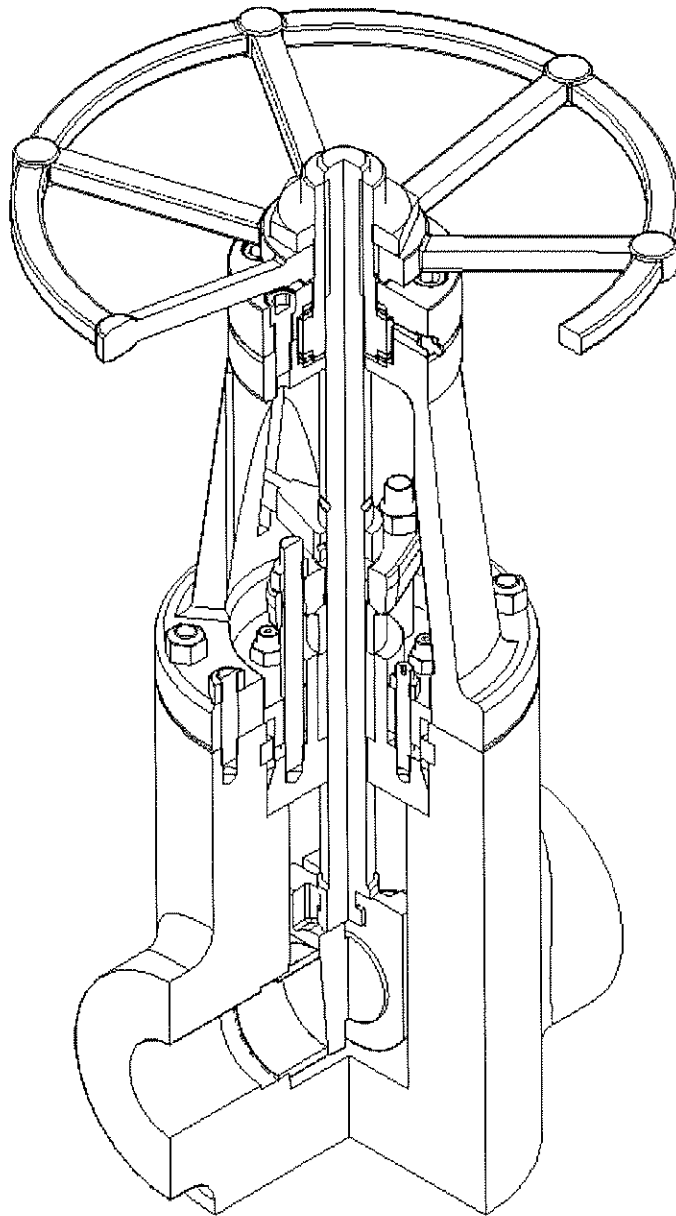

**DOUGLAS/CHERO**  
**dc** FORGED VALVES

**Douglas Chero** was established in 1974 to meet the demand for high quality forged valves in the petroleum refining and production plants, offshore oil and gas fields, power industry, fertilizer, chemical and desalination plants all over the world. Production capacity increased from 3,000 pieces in 1974 to current 40,000 pieces per month in our new factory with modern state of the art machining facilities and manufacturing technology.

The factory is 30,000 sq.m. (330,000 sq.ft.) of which 9,000 sq.m. (100,000 sq.ft.) are covered.

Douglas Chero Gate, Globe, Check forged valves in Pressure Seal execution have been designed for high temperatures and high pressure applications in all types of power plants as well as for chemical and petrochemical plants.

The high quality forged materials are more reliable for severe applications if compared to cast materials and the advanced design of Douglas Chero Pressure Seal valves guarantees the best performance and the best tightness at the worst conditions of service. Furthermore, the one piece body design eliminates any potential risk of leakage through welded components.

## Quality

The high quality of Douglas Chero valves is recognized everywhere since more than 30 years.

Not only the quality is guaranteed on the manufactured valves but every process and step from procurement through machining, assembly and testing is driven by our continued commitment for innovation through quality in accordance with the written rules of our QA manual and as per ISO 9001: 2000 .

## Main Technical Characteristics:

- **Rating:** From 900# to 4500#  
Standard class or Special class as per ASME B16.34
- **End connections:** BW as per ASME B16.25
- **Materials:** A105N, F11, F22, F91, F92, F316 ....  
Others upon request ....
- **Size:** From 1/2" to 12"
- **Operation:** Handweel  
Bevel Gear  
Electric actuator

## Head Office & Factory

Località Pradaglie - 29013 Carpaneto (PC) - Italy  
Tel. +39-0523-854011 - Fax +39-0523-850389  
E-mail sales@douglas-cherro.com  
www.douglas-cherro.com

Valves are CE marked  
according to PED 97/23/CE



VALVES ARE MANUFACTURED ACCORDING TO ISO 9001:2000  
CERTIFIED BY DET NORSKE VERITAS WITH CERTIFICATE

No. CERT-00026-92-AQ-MIL-SINCERT

COMPANY  
WITH QUALITY SYSTEM  
CERTIFIED BY DNV  
**== ISO 9001 ==**



VALVES ARE MANUFACTURED ACCORDING TO TÜV AD 2000-  
Merkblatt HP 0 REGISTRATION No. 04 202 H 410 05 00011



# Products

---

**Ratings (ASTM A105)**

 1500 p.s.i. @ 850°F  
 3705 p.s.i. @ 100°F

**Test pressure (ASTM A105)**
**Hydraulic:(minimum)**  
 Body - 5575 p.s.i.  
 Seat - 4100 p.s.i.  
**Air under water:**  
 Seat - 85 p.s.i.

**Standards**
**Construction** *founded on ASME B16.34*  
**Socket weld** ASME B16.11  
**Butt weld** ASME B16.25  
**Test** ASME B16.34

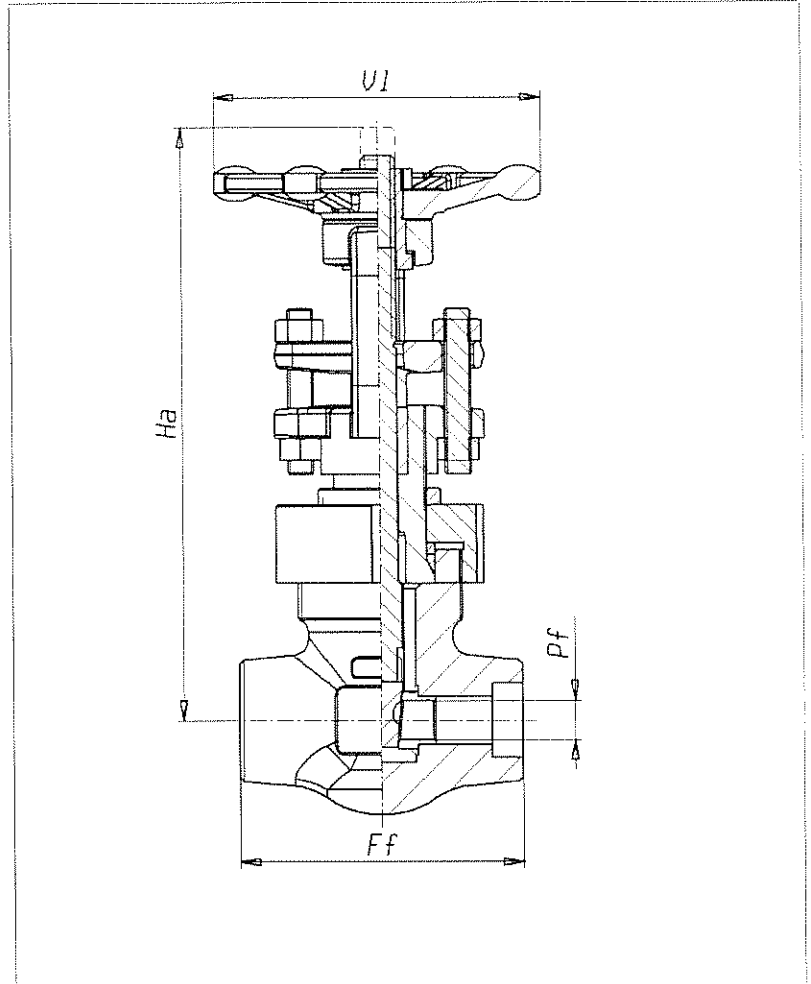
**Connections (xx)**
**SW** Socket weld  
**B4** Butt weld 40  
**B8** Butt weld 80  
**B6** Butt weld 160  
**BX** Butt weld XXS

**STANDARD BORE**

			1/2"	3/4"	1"		1.1/2"	2"
Ff (mm/in)			110 4,33	115 4,53	130 5,12		210 8,27	240 9,45
Ha (mm/in)			219 8,62	263 10,3	278 10,9		400 15,75	414 16,30
V1 (mm/in)			120 4,72	175 6,89	175 6,89		225 8,86	250 9,84
Pf (mm/in)			11,5 0,45	15 0,59	19,5 0,77		32 1,26	40 1,57
Wt. (kg/lb)			5,9 13,1	8,4 18,5	9,8 21,6		26,8 59,0	35 78
Catal. no.			652PS/xx	653PS/xx	654PS/xx		656PS/xx	657PS/xx

1) Complete Pressure-Temperature ratings on page 24, 25

**Ratings (ASTM A105)**

 1500 p.s.i. @ 850°F  
 3705 p.s.i. @ 100°F

**Test pressure (ASTM A105)**
**Hydraulic: (minimum)**  
 Body - 5575 p.s.i.  
 Seat - 4100 p.s.i.  
**Air under water:**  
 Seat - 85 p.s.i.

**Standards**
**Construction** *founded on ASME B16.34*  
**Socket weld** ASME B16.11  
**Butt weld** ASME B16.25  
**Test** ASME B16.34

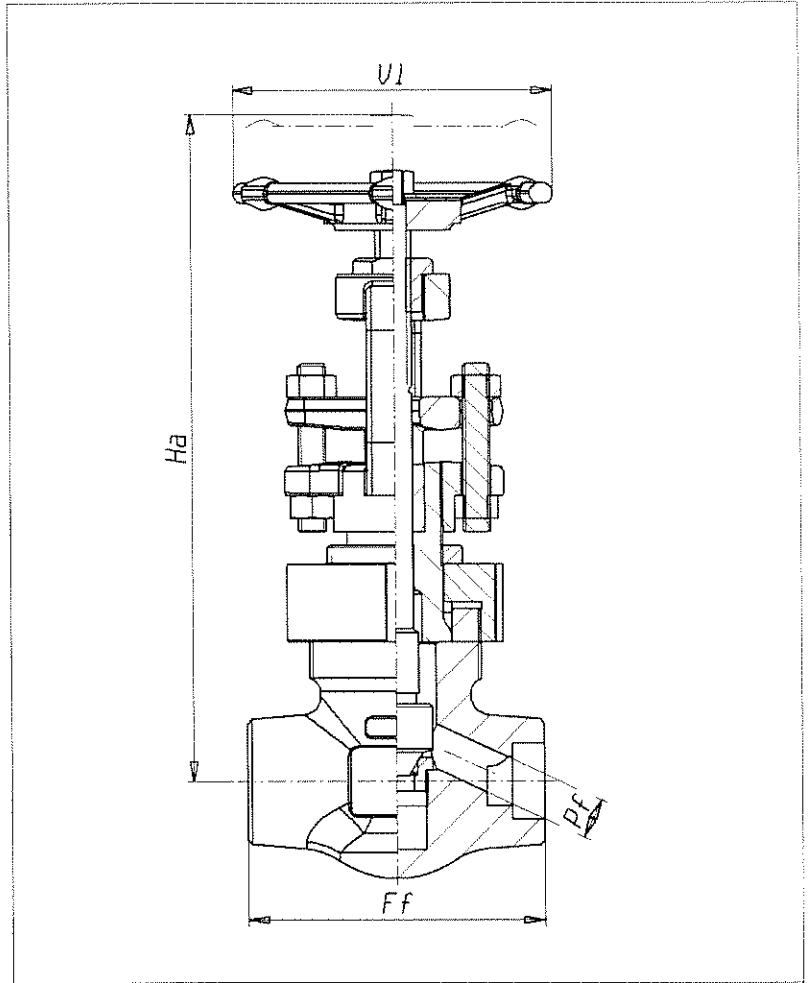
**Connections (xx)**
**SW** Socket weld  
**B4** Butt weld 40  
**B8** Butt weld 80  
**B6** Butt weld 160  
**BX** Butt weld XXS

**STANDARD BORE**

			1/2"	3/4"	1"		1.1/2"	2"
Ff (mm/in)			110 4,33	115 4,53	130 5,12		210 8,27	240 9,45
Ha (mm/in)			223 8,78	270 10,6	286 11,2		408 16,06	420 16,53
V1 (mm/in)			120 4,72	140 4,53	140 4,53		260 10,2	260 10,2
Pf (mm/in)			11,0 0,43	14 0,55	18,0 0,71		30 1,18	35 1,38
Wt. (kg/lb)			4,7 10,3	7,4 16,3	8,4 18,5		24,8 54,6	26 57
Catal. no.			752PS/xx	753PS/xx	754PS/xx		756PS/xx	757PS/xx

1) Complete Pressurtemperature ratings on page 24, 25

**Ratings (ASTM A105)**

 2500 p.s.i. @ 850°F  
 6170 p.s.i. @ 100°F

**Test pressure (ASTM A105)**
**Hydraulic:(minimum)**  
 Body - 9275 p.s.i.  
 Seat - 6800 p.s.i.  
**Air under water:**  
 Seat - 85 p.s.i.

**Standards**
**Construction** *founded on ASME B16.34*  
**Socket weld** ASME B16.11  
**Butt weld** ASME B16.25  
**Test** ASME B16.34

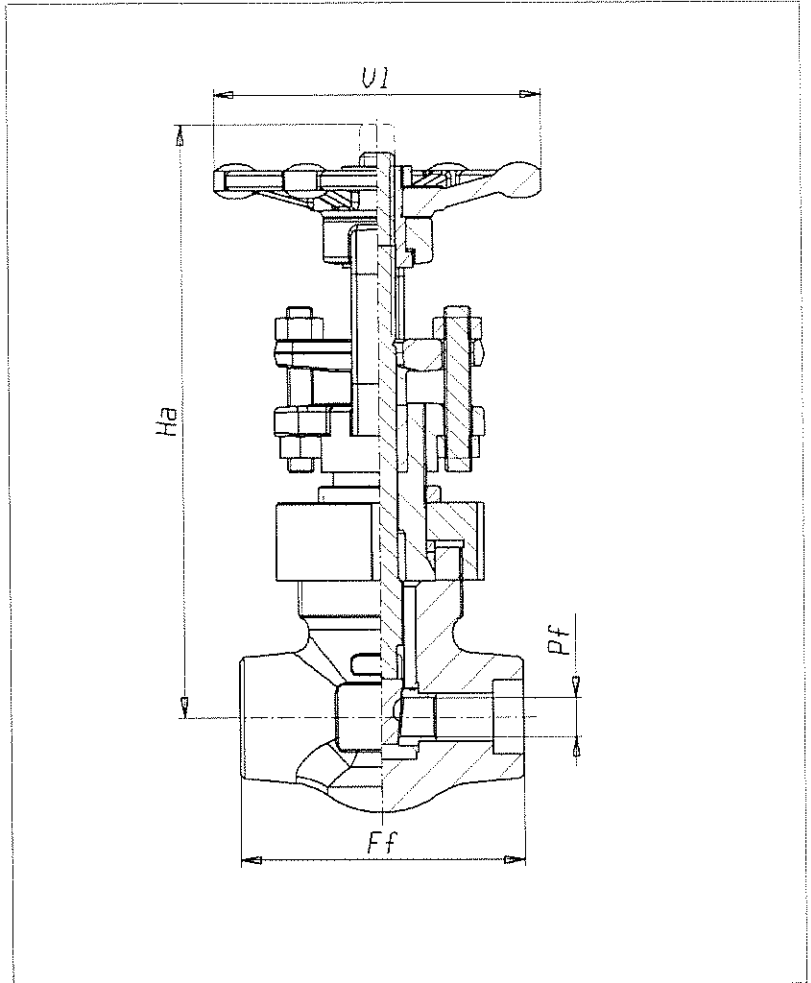
**Connections (xx)**
**SW** Socket weld  
**B4** Butt weld 40  
**B8** Butt weld 80  
**B6** Butt weld 160  
**BX** Butt weld XXS

**STANDARD BORE**

			1/2"		3/4"		1"			1.1/2"		2"	
Ff (mm/in)			110	4,33	115	4,53	130	5,12		210	8,27	240	9,45
Ha (mm/in)			233	9,17	272	10,7	287	11,3		398	15,67	438	17,24
VI (mm/in)			140	5,51	175	6,89	175	6,89		250	9,84	350	13,7
Pf (mm/in)			10,0	0,39	14	0,55	18,0	0,71		31	1,22	36.5	1,44
Wt. (kg/lb)			6,1	13,4	8,7	19,1	10,2	22,4		27,4	60,4	36	79,8
Catal. no.			1052PS/xx		1053PS/xx		1054PS/xx			1056PS/xx		1057PS/xx	

1) Complete Pressure-Temperature ratings on page 24, 25

**Ratings (ASTM A105)**

2500 p.s.i. @ 850°F  
6170 p.s.i. @ 100°F

**Test pressure (ASTM A105)**

**Hydraulic:** (minimum)  
Body - 9275 p.s.i.  
Seat - 6800 p.s.i.  
**Air under water:**  
Seat - 85 p.s.i.

**Standards**

**Construction** founded on ASME B16.34  
**Socket weld** ASME B16.11  
**Butt weld** ASME B16.25  
**Test** ASME B16.34

**Connections (xx)**

**SW** Socket weld  
**B4** Butt weld 40  
**B8** Butt weld 80  
**B6** Butt weld 160  
**BX** Butt weld XXS

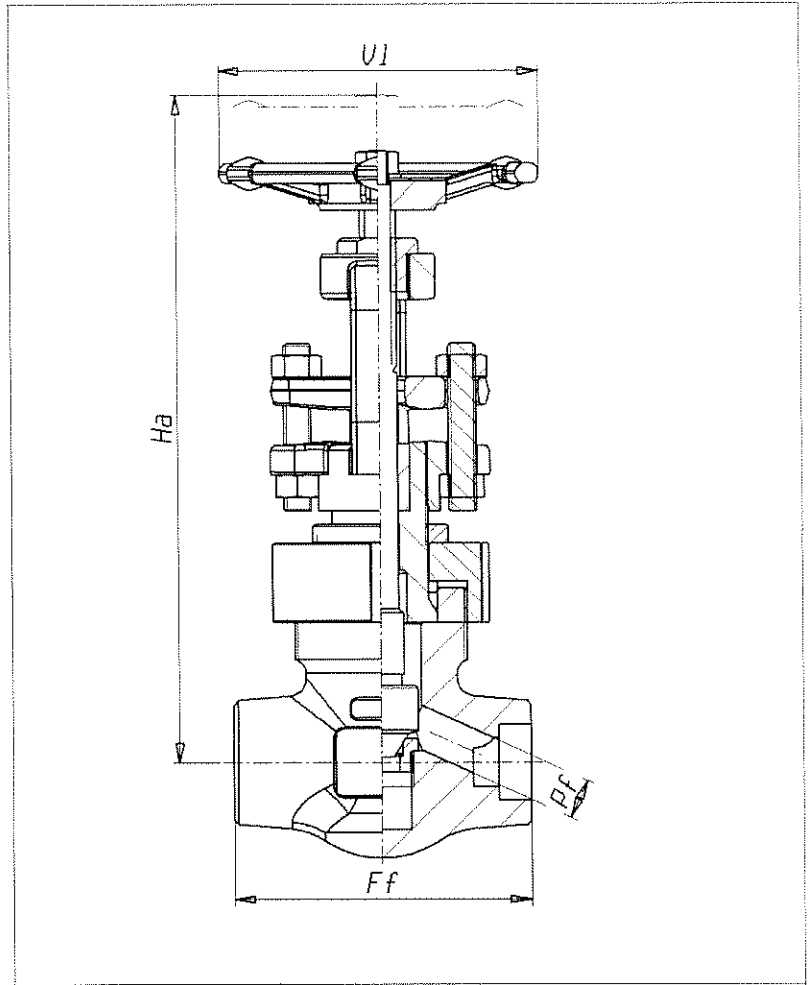
**STANDARD BORE**

			1/2"	3/4"	1"		1.1/2"	2"
<b>Ff (mm/in)</b>			110 4,33	115 4,53	130 5,12		210 8,27	240 9,45
<b>Ha (mm/in)</b>			238 9,37	276 10,8	295 11,6		406 15,98	437 17,20
<b>VI (mm/in)</b>			120 4,72	200 7,87	200 7,87		260 10,2	350 13,7
<b>Pf (mm/in)</b>			11,0 0,43	14 0,55	18,0 0,71		30 1,18	35 1,38
<b>Wt. (kg/lb)</b>			5,7 12,5	7,9 17,4	9,2 20,2		29,1 64,1	35 78
<b>Catal. no.</b>			1152PS/xx	1153PS/xx	1154PS/xx		1156PS/xx	1157PS/xx

1) Complete Pressure-Temperature ratings on page 24, 25



**Ratings (ASTM A105)**

900 p.s.i. @ 850°F  
2220 p.s.i. @ 100°F

**Test pressure (ASTM A105)**

**Hydraulic:** (minimum)  
Body - 3330 p.s.i.  
Seat - 2442 p.s.i.  
**Air under water:**  
Seat - 85 p.s.i.

**Standards**

**Construction** founded on API 600  
**Socket weld** ASME B16.11  
**Butt weld** ASME B16.25  
**Test** API 598, BS EN 12266 (Pt.1)

**Connections (xx)**

**SW** Socket weld  
**B4** Butt weld 40  
**B8** Butt weld 80  
**B6** Butt weld 160  
**BX** Butt weld XXS

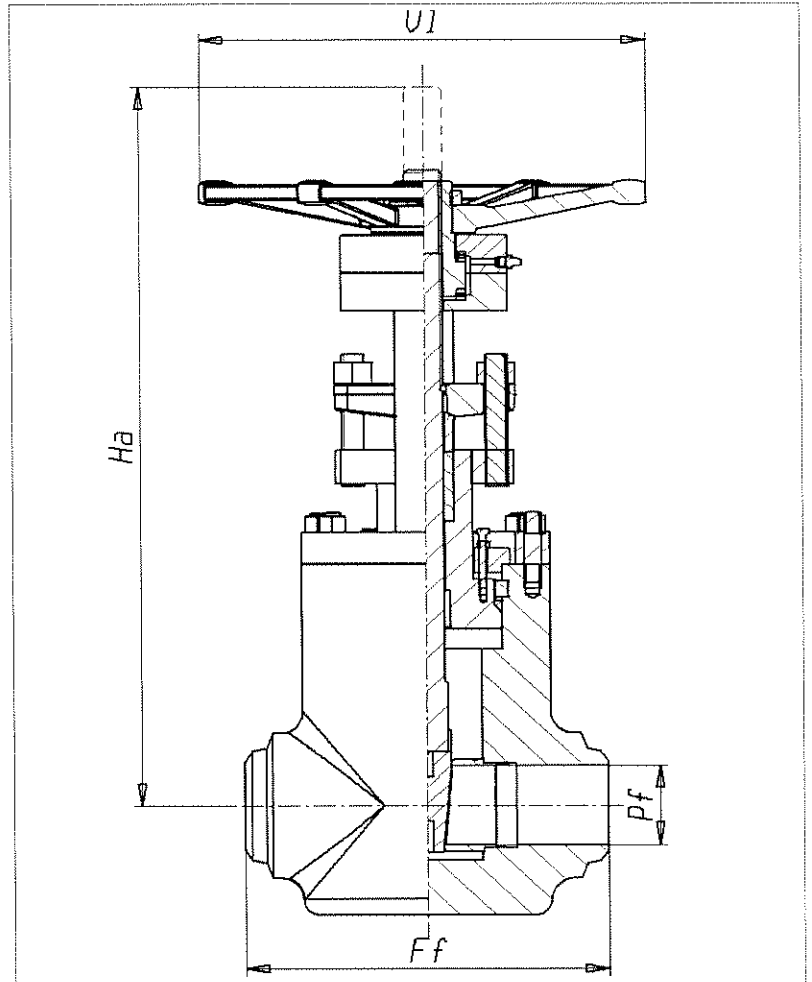
**STANDARD BORE**

			3"	4"	6"	8"	10"	12"
Ff (mm/in)			305 12,0	356 14,0	508 20,0	660 25,9	787 30,9	864 34,0
Ha (mm/in)			600 23,6	660 25,9	1000 39,3	1300 51,1	1495 58,8	1690 66,5
VI (mm/in)			350 13,7	350 13,7	BGR	BGR	BGR	BGR
Pf (mm/in)			72 2,83	98 3,85	146 5,74	190 7,48	210 8,26	245 9,64
Wt. (kg/lb)			85 187	160 352	410 902	737 1621	980 2156	1545 3399
Catal. no.			60BPS/xx	60CPS/xx	60APS/xx	60GPS/xx	60HPS/xx	60JPS/xx

1) Complete Pressure-Temperature ratings on page 24, 25  
2) BGR: with gear operator

**Ratings (ASTM A105)**

900 p.s.i. @ 850°F  
2220 p.s.i. @ 100°F

**Test pressure (ASTM A105)**

**Hydraulic:** (minimum)  
Body - 3330 p.s.i.  
Seat - 2442 p.s.i.  
**Air under water:**  
Seat - 85 p.s.i.

**Standards**

**Construction** founded on BS 1873  
**Socket weld** ASME B16.11  
**Butt weld** ASME B16.25  
**Test** API 598, BS EN 12266 (Pt. 1)

**Connections (xx)**

**SW** Socket weld  
**B4** Butt weld 40  
**B8** Butt weld 80  
**B6** Butt weld 160  
**BX** Butt weld XXS

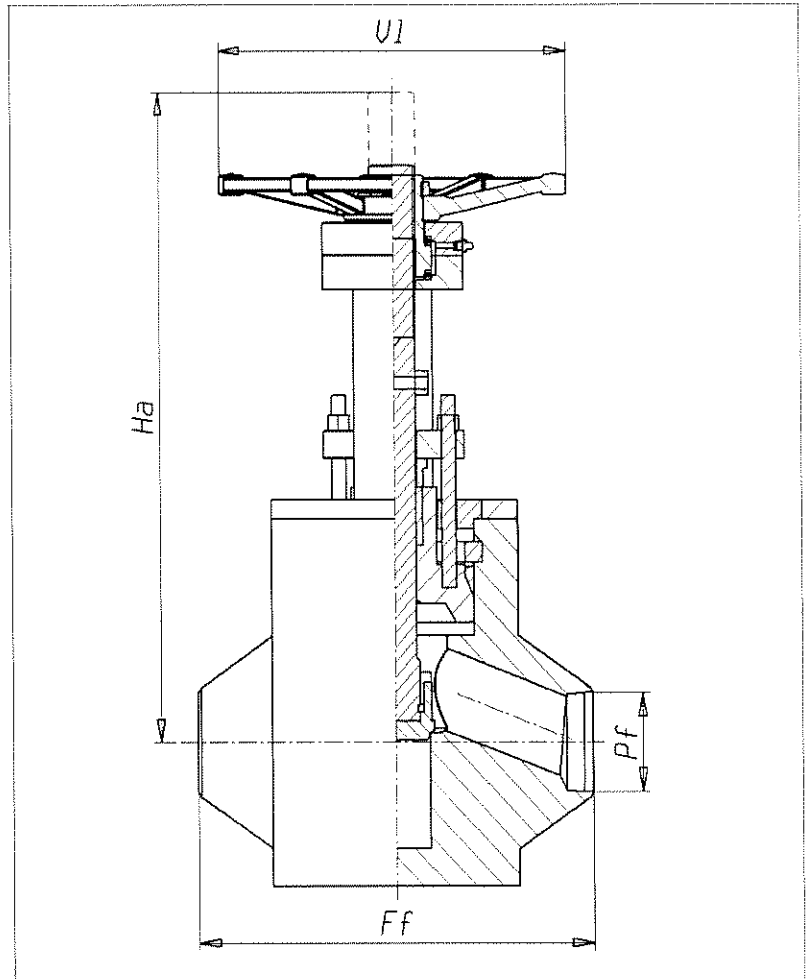
**STANDARD BORE**

			3"	4"	6"	8"	10"	12"
Ff (mm/in)			305 12,0	356 14,0	508 20,0	660 25,9	838 32,9	965 37,9
Ha (mm/in)			600 23,6	650 25,5	750 29,5	1000 39,3	1750 68,8	1970 77,5
U1 (mm/in)			350 13,7	350 13,7	BGR	BGR	BGR	BGR
Pf (mm/in)			78 3,07	102 4,01	154 6,06	180 7,08	195 7,67	231 9,09
Wt. (kg/lb)			90 198	170 374	430 946	750 1650	1195 2629	1910 4202
Catal. no.			70BPS/xx	70CPS/xx	70APS/xx	70GPS/xx	70HPS/xx	70JPS/xx

1) Complete Pressure-Temperature ratings on page 24, 25  
2) BGR: with gear operator

**Ratings (ASTM A105)**

1500 p.s.i. @ 850°F  
3705 p.s.i. @ 100°F

**Test pressure (ASTM A105)**

**Hydraulic:** (minimum)  
Body - 5557 p.s.i.  
Seat - 4075 p.s.i.  
**Air under water:**  
Seat - 85 p.s.i.

**Standards**

**Construction** founded on API 600  
**Socket weld** ASME B16.11  
**Butt weld** ASME B16.25  
**Test** API 598, BS EN 12266 (Pt.1)

**Connections (xx)**

**SW** Socket weld  
**B4** Butt weld 40  
**B8** Butt weld 80  
**B6** Butt weld 160  
**BX** Butt weld XXS

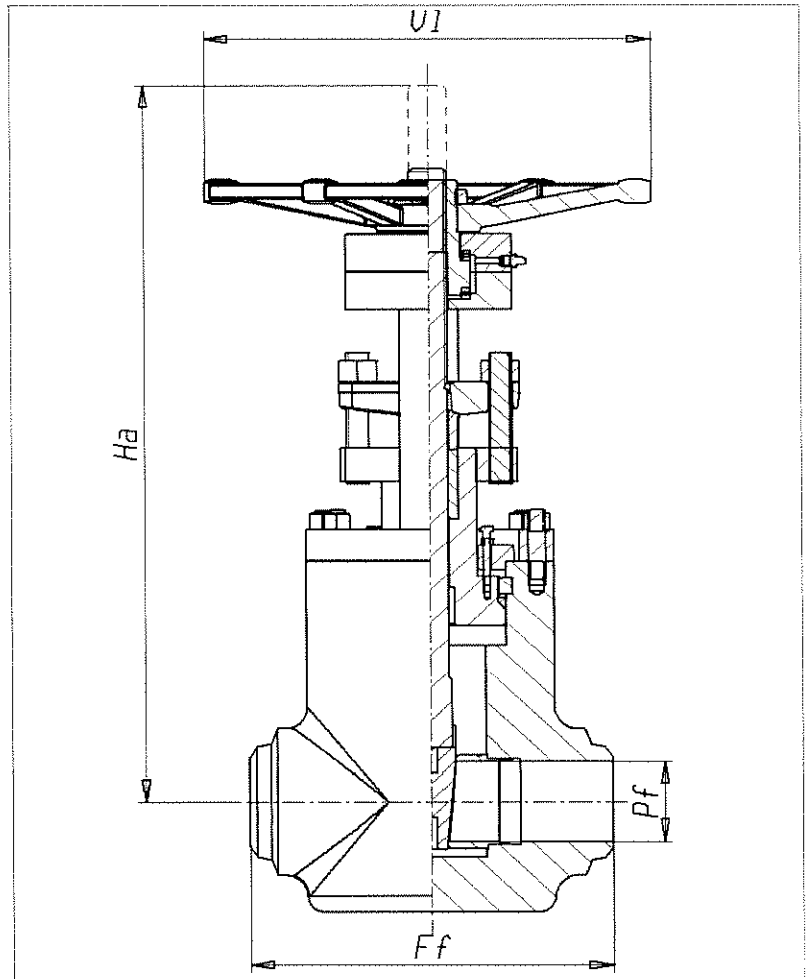
**STANDARD BORE**

			3"	4"	6"	8"	10"	12"
<b>Ff (mm/in)</b>			305 12,0	406 15,9	559 22,0	711 27,9	864 34,0	864 34,0
<b>Ha (mm/in)</b>			630 24,8	690 27,1	1100 43,3	1350 53,1	1495 58,8	1690 66,5
<b>U1 (mm/in)</b>			350 13,7	350 13,7	BGR	BGR	BGR	BGR
<b>Pf (mm/in)</b>			69 2,71	98 3,85	137 5,39	178 7,00	210 8,26	245 9,64
<b>Wt. (kg/lb)</b>			90 198	170 374	430 946	750 1650	1015 2233	1545 3399
<b>Catal. no.</b>			65BPS/xx	65CPS/xx	65APS/xx	65GPS/xx	65HPS/xx	65JPS/xx

1) Complete Pressure-Temperature ratings on page 24, 25  
2) BGR: with gear operator

**Ratings (ASTM A105)**

1500 p.s.i. @ 850°F  
3705 p.s.i. @ 100°F

**Test pressure (ASTM A105)**

**Hydraulic:** (minimum)  
Body - 5557 p.s.i.  
Seat - 4075 p.s.i.  
**Air under water:**  
Seat - 85 p.s.i.

**Standards**

**Construction** founded on BS 1873  
**Socket weld** ASME B16.11  
**Butt weld** ASME B16.25  
**Test** API 598, BS EN 12266 (Pt.1)

**Connections (xx)**

**SW** Socket weld  
**B4** Butt weld 40  
**B8** Butt weld 80  
**B6** Butt weld 160  
**BX** Butt weld XXS

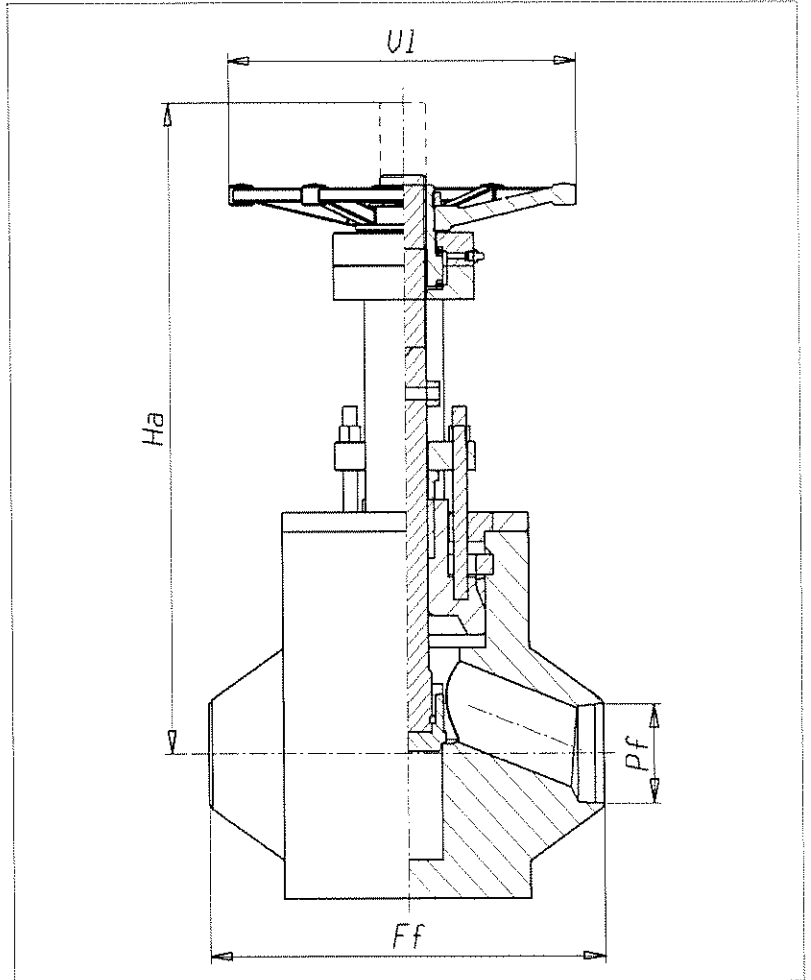
**STANDARD BORE**

			3"	4"	6"	8"	10"	12"
Ff (mm/in)			305 12,0	406 15,9	559 22,0	711 27,9	991 39,0	1130 44,4
Ha (mm/in)			600 23,6	650 25,5	750 29,5	1000 39,3	1410 55,5	1590 62,5
U1 (mm/in)			350 13,7	350 13,7	BGR	BGR	BGR	BGR
Pf (mm/in)			78 3,07	102 4,01	154 6,06	180 7,08	195 7,67	231 9,09
Wt. (kg/lb)			90 198	170 374	430 946	750 1650	1250 2750	1980 4356
Catal. no.			75BPS/xx	75CPS/xx	75APS/xx	75GPS/xx	75HPS/xx	75JPS/xx

1) Complete Pressure-Temperature ratings on page 24, 25  
2) BGR: with gear operator

**Ratings (ASTM A105)**

2500 p.s.i. @ 850°F  
6170 p.s.i. @ 100°F

**Test pressure (ASTM A105)**

**Hydraulic:** (minimum)  
Body - 9255 p.s.i.  
Seat - 6787 p.s.i.  
**Air under water:**  
Seat - 85 p.s.i.

**Standards**

**Construction** founded on API 600  
**Socket weld** ASME B16.11  
**Butt weld** ASME B16.25  
**Test** API 598, BS EN 12266 (Pt.1)

**Connections (xx)**

**SW** Socket weld  
**B4** Butt weld 40  
**B8** Butt weld 80  
**B6** Butt weld 160  
**BX** Butt weld XXS

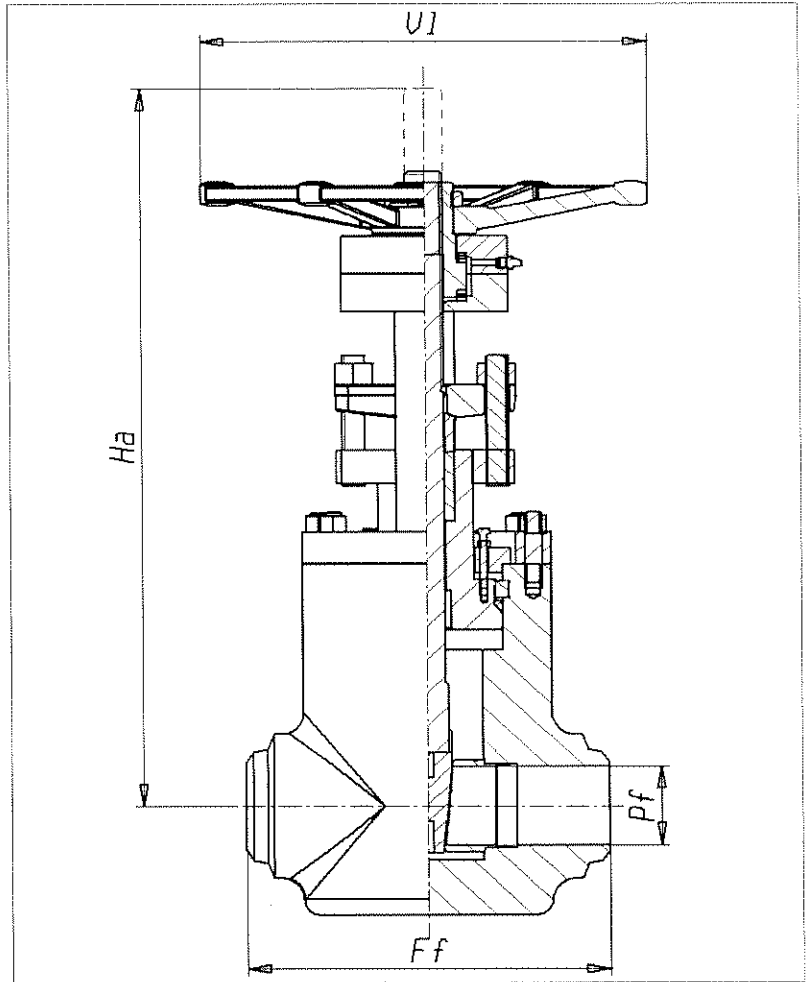
**STANDARD BORE**

			3"	4"	6"	8"	10"	12"
Ff (mm/in)			368 14,4	457 17,9	610 24,0	762 30,0	864 34,0	864 34,0
Ha (mm/in)			600 23,6	660 25,9	1000 39,3	1300 51,1	1400 55,1	1770 69,6
VI (mm/in)			350 13,7	BGR	BGR	BGR	BGR	BGR
Pf (mm/in)			57 2,24	73 2,87	111 4,37	146 5,74	184 7,24	218 8,58
Wt. (kg/lb)			95 209	170 374	430 946	790 1738	1400 3080	1850 4070
Catal. no.			105BPS/xx	105CPS/xx	105APS/xx	105GPS/xx	105HPS/xx	105JPS/xx

1) Complete Pressure-Temperature ratings on page 24, 25  
2) BGR: with gear operator

**Ratings (ASTM A105)**

2500 p.s.i. @ 850°F  
6170 p.s.i. @ 100°F

**Test pressure (ASTM A105)**

**Hydraulic:** (minimum)  
Body - 9255 p.s.i.  
Seat - 6787 p.s.i.  
**Air under water:**  
Seat - 85 p.s.i.

**Standards**

**Construction** founded on BS 1873  
**Socket weld** ASME B16.11  
**Butt weld** ASME B16.25  
**Test** API 598, BS EN 12266 (Pt.1)

**Connections (xx)**

**SW** Socket weld  
**B4** Butt weld 40  
**B8** Butt weld 80  
**B6** Butt weld 160  
**BX** Butt weld XXS

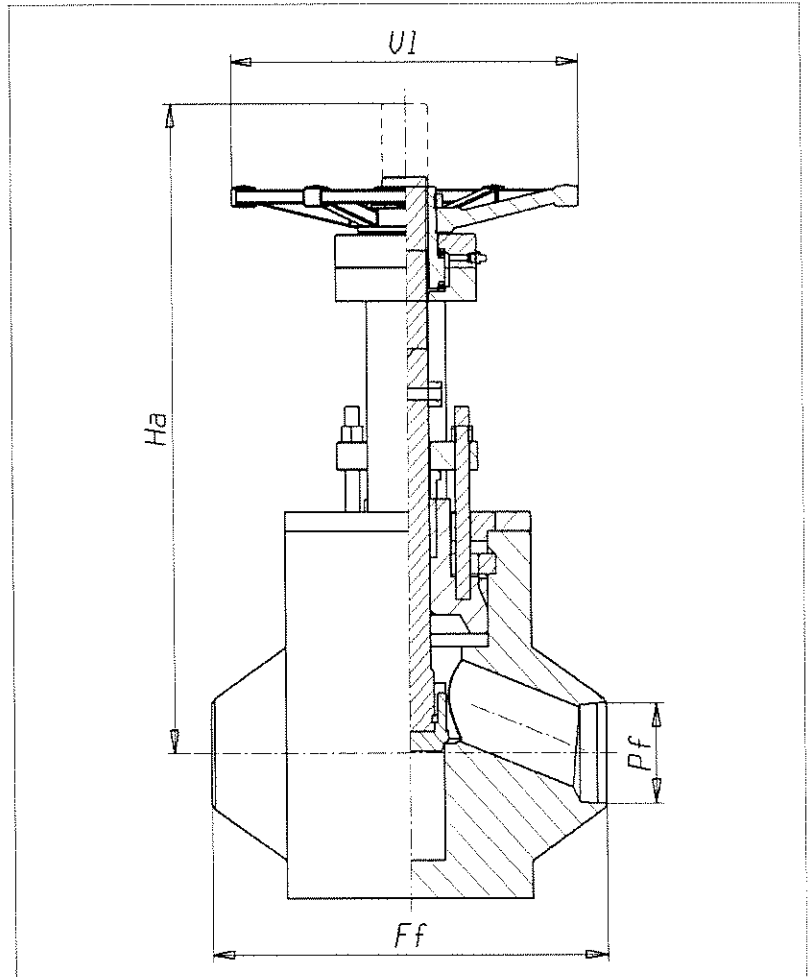
**STANDARD BORE**

			3"	4"	6"	8"	10"	12"
Ff (mm/in)			368 14,4	457 17,9	610 24,0	762 30,0	914 35,9	1041 40,9
Ha (mm/in)			600 23,6	660 25,9	800 31,4	1100 43,3	1500 59,0	1950 76,7
U1 (mm/in)			350 13,7	BGR	BGR	BGR	BGR	BGR
Pf (mm/in)			78 3,07	102 4,01	154 6,06	180 7,08	200 7,8	220 8,6
Wt. (kg/lb)			95 209	170 374	430 946	790 1738	1500 3300	2000 4400
Catal. no.			115BPS/xx	115CPS/xx	115APS/xx	115GPS/xx	115HPS/xx	115JPS/xx

1) Complete Pressure-Temperature ratings on page 24, 25  
2) BGR: with gear operator

### Ratings (ASTM A105)

900 p.s.i. @ 850°F  
2220 p.s.i. @ 100°F

### Test pressure (ASTM A105)

**Hydraulic: (minimum)**  
Body - 3330 p.s.i.  
Seat - 2442 p.s.i.  
**Air under water:**  
Seat - 85 p.s.i.

### Standards

**Construction** *founded on* BS 1873  
**Socket weld** ASME B16.11  
**Butt weld** ASME B16.25  
**Test** API 598, BS EN 12266 (Pt.1)

### Connections (xx)

**SW** Socket weld  
**B4** Butt weld 40  
**B8** Butt weld 80  
**B6** Butt weld 160  
**BX** Butt weld XXS

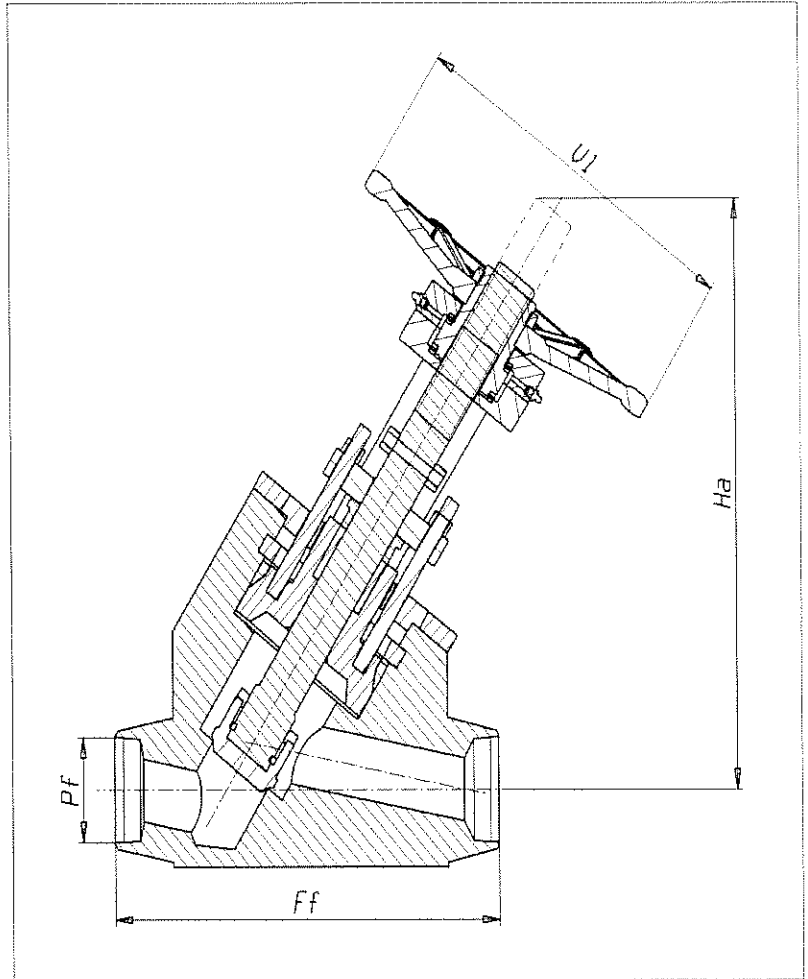

### STANDARD BORE

			3"	4"	6"	8"		
Ff (mm/in)			350 13,7	400 15,7	500 19,6	625 24,6		
Ha (mm/in)			450 17,7	510 20,0	630 24,8	825 32,4		
Vl (mm/in)			350 13,7	350 13,7	BGR	BGR		
Pf (mm/in)			78 3,07	102 4,01	154 6,06	202 7,95		
Wt. (kg/lb)			90 198	120 264	430 946	750 1650		
Catal. no.			Y70BPS/xx	Y70CPS/xx	Y70APS/xx	Y70GPS/xx		

1) Complete Pressure-Temperature ratings on page 24, 25  
2) BGR: with gear operator

**Ratings (ASTM A105)**

1500 p.s.i. @ 850°F  
3705 p.s.i. @ 100°F

**Test pressure (ASTM A105)**

**Hydraulic:** (minimum)  
Body - 5557 p.s.i.  
Seat - 4075 p.s.i.  
**Air under water:**  
Seat - 85 p.s.i.

**Standards**

**Construction** founded on BS 1873  
**Socket weld** ASME B16.11  
**Butt weld** ASME B16.25  
**Test** API 598, BS EN 12266 (Pt.1)

**Connections (xx)**

**SW** Socket weld  
**B4** Butt weld 40  
**B8** Butt weld 80  
**B6** Butt weld 160  
**BX** Butt weld XXS

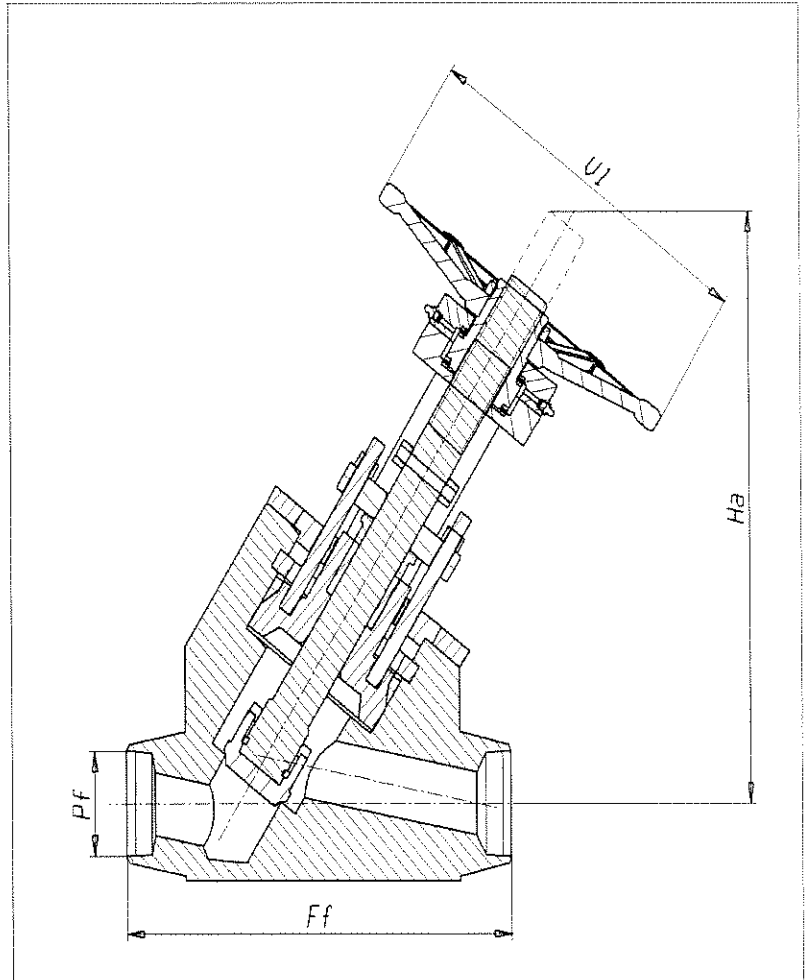

**STANDARD BORE**

			3"	4"	6"	8"		
Ff (mm/in)			350 13,7	400 15,7	500 19,6	625 24,6		
Ha (mm/in)			450 17,7	510 20,0	630 24,8	825 32,4		
VI (mm/in)			350 13,7	500 19,6	BGR	BGR		
Pf (mm/in)			78 3,07	102 4,01	154 6,06	202 7,95		
Wt. (kg/lb)			90 198	170 374	430 946	750 1650		
Catal. no.			Y75BPS/xx	Y75CPS/xx	Y75APS/xx	Y75GPS/xx		

1) Complete Pressure-Temperature ratings on page 24, 25  
2) BGR: with gear operator



### Ratings (ASTM A105)

2500 p.s.i. @ 850°F  
6170 p.s.i. @ 100°F

### Test pressure (ASTM A105)

**Hydraulic:** (minimum)  
Body - 9255 p.s.i.  
Seat - 6787 p.s.i.  
**Air under water:**  
Seat - 85 p.s.i.

### Standards

**Construction** founded on BS 1873  
**Socket weld** ASME B16.11  
**Butt weld** ASME B16.25  
**Test** API 598, BS EN 12266 (Pt.1)

### Connections (xx)

**SW** Socket weld  
**B4** Butt weld 40  
**B8** Butt weld 80  
**B6** Butt weld 160  
**BX** Butt weld XXS

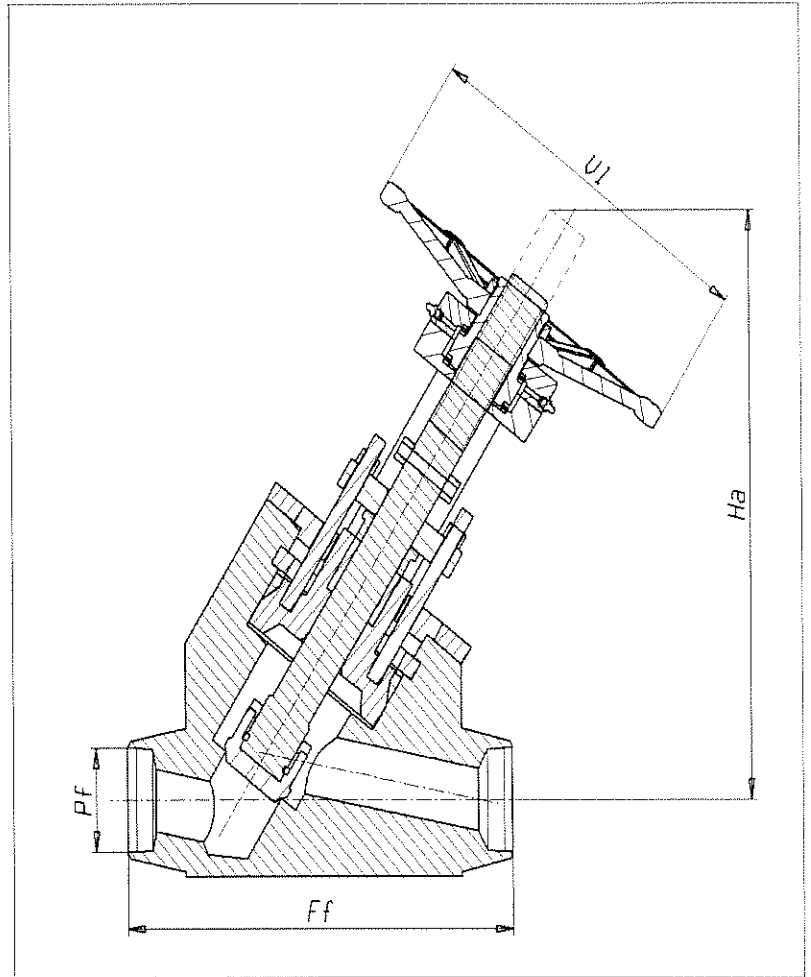

### STANDARD BORE

		3"	4"	6"	8"		
Ff (mm/in)		350 13,7	400 15,7	500 19,6	625 24,6		
Ha (mm/in)		450 17,7	510 20,0	630 24,8	825 32,4		
Vl (mm/in)		350 13,7	BGR	BGR	BGR		
Pf (mm/in)		78 3,07	102 4,01	154 6,06	202 7,95		
Wt. (kg/lb)		95 209	170 374	430 946	790 1738		
Catal. no.		Y115BPS/xx	Y115CPS/xx	Y115APS/xx	Y115GPS/xx		

1) Complete Pressure-Temperature ratings on page 24, 25

2) BGR: with gear operator

### Ratings (ASTM A105)

1500 p.s.i. @ 850°F  
3705 p.s.i. @ 100°F

### Test pressure (ASTM A105)

**Hydraulic: (minimum)**  
Body - 5575 p.s.i.  
Seat - 4100 p.s.i.  
**Air under water:**  
Seat - 85 p.s.i.

### Standards

**Construction** founded on ASME B16.34  
**Socket weld** ASME B16.11  
**Butt weld** ASME B16.25  
**Test** ASME B16.34

### Connections (xx)

**SW** Socket weld  
**B4** Butt weld 40  
**B8** Butt weld 80  
**B6** Butt weld 160  
**BX** Butt weld XXS

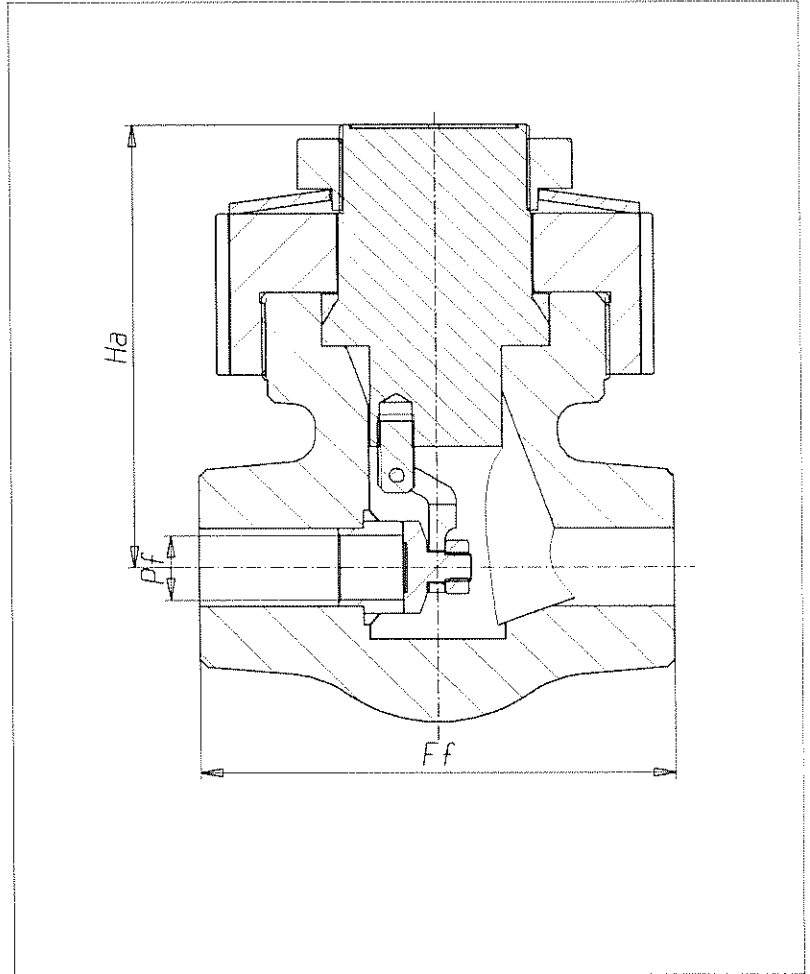

### STANDARD BORE

			1/2"	3/4"	1"		1.1/2"	2"
Ff (mm/in)			110 4,33	115 4,53	130 5,12		210 8,27	240 9,45
Ha (mm/in)			86 3,38	100 3,93	110 4,33		153 6,02	170 6,69
Pf (mm/in)			11,5 0,45	15 0,59	19,5 0,77		32 1,26	40 1,57
Wt. (kg/lb)			2,9 6,38	4,2 9,24	5,4 11,8		17,7 38,9	22 48,3
Catal. no.			852PS/xx	853PS/xx	854PS/xx		856PS/xx	857PS/xx

1) Complete Pressure/temperature ratings on page 24, 25

### Ratings (ASTM A105)

2500 p.s.i. @ 850°F  
6170 p.s.i. @ 100°F

### Test pressure (ASTM A105)

**Hydraulic: (minimum)**  
Body - 9275 p.s.i.  
Seat - 6800 p.s.i.  
**Air under water:**  
Seat - 85 p.s.i.

### Standards

**Construction** *founded on ASME B16.34*  
**Socket weld** ASME B16.11  
**Butt weld** ASME B16.25  
**Test** ASME B16.34

### Connections (xx)

**SW** Socket weld  
**B4** Butt weld 40  
**B8** Butt weld 80  
**B6** Butt weld 160  
**BX** Butt weld XXS

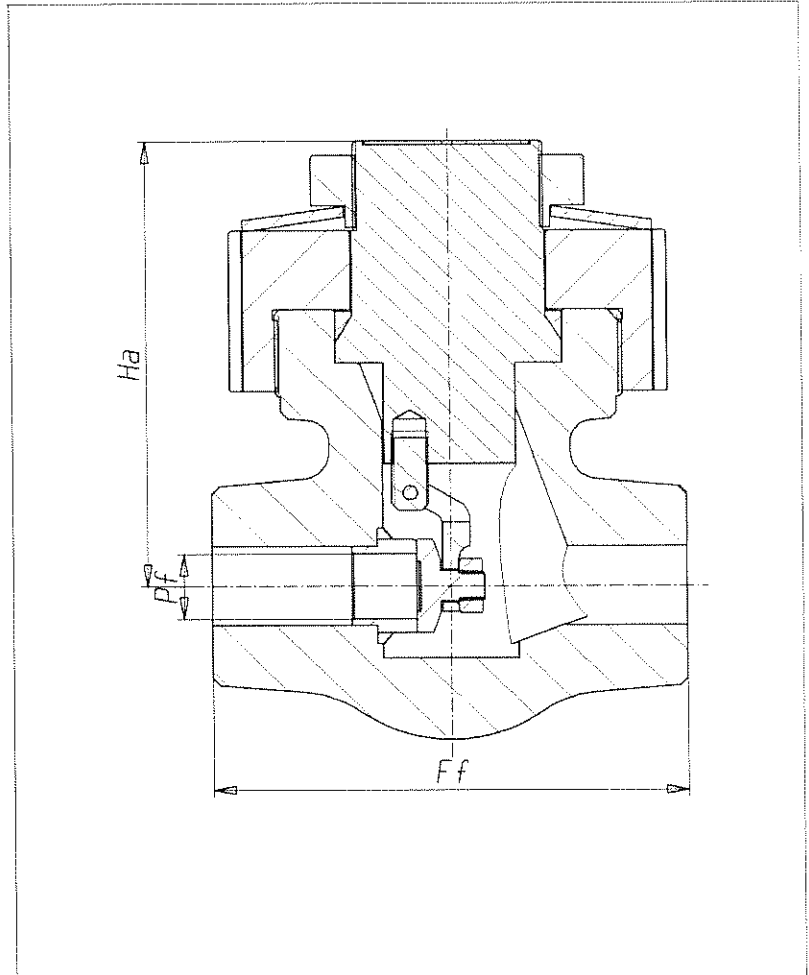

### STANDARD BORE

			1/2"	3/4"	1"		1.1/2"	2"
<b>Ff (mm/in)</b>			110 4,33	115 4,53	130 5,12		210 8,27	240 9,45
<b>Ha (mm/in)</b>			90 3,54	100 3,93	124 4,88		164 6,45	170 6,69
<b>Pf (mm/in)</b>			10,0 0,39	14 0,55	18,0 0,71		31 1,22	36,5 1,44
<b>Wt. (kg/lb)</b>			2,9 6,38	4,2 9,24	5,4 11,8		17,7 38,9	22 48,3
<b>Catal. no.</b>			2152PS/xx	2153PS/xx	2154PS/xx		2156PS/xx	2157PS/xx

1) Complete Pressurtemperature ratings on page 24, 25

### Ratings (ASTM A105)

900 p.s.i. @ 850°F  
2220 p.s.i. @ 100°F

### Test pressure (ASTM A105)

**Hydraulic:** (minimum)  
Body - 3330 p.s.i.  
Seat - 2442 p.s.i.  
**Air under water:**  
Seat - 85 p.s.i.

### Standards

**Construction** founded on BS 1873  
**Socket weld** ASME B16.11  
**Butt weld** ASME B16.25  
**Test** API 598, BS EN 12266 (Pt.1)

### Connections (xx)

**SW** Socket weld  
**B4** Butt weld 40  
**B8** Butt weld 80  
**B6** Butt weld 160  
**BX** Butt weld XXS

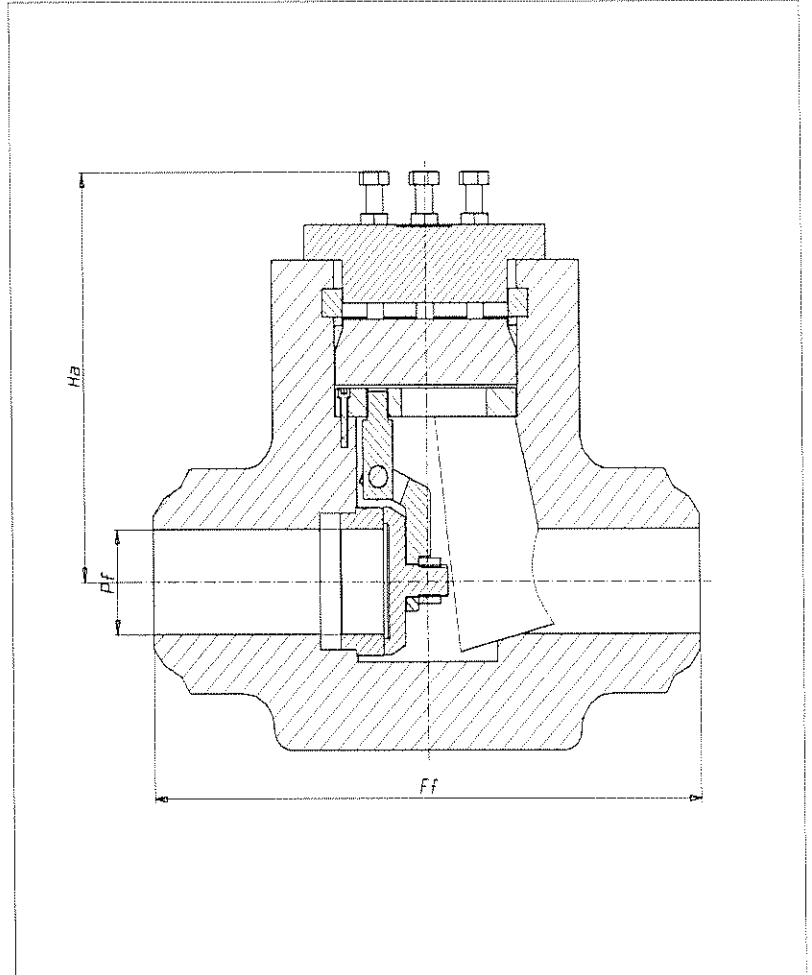

### STANDARD BORE

			3"	4"	6"	8"	10"	12"
Ff (mm/in)			305 12,0	356 14,0	508 20,0	660 25,9	787 30,9	864 34,0
Ha (mm/in)			220 8,66	323 12,7	400 15,7	450 17,7	505 19,8	590 23,2
Pf (mm/in)			72 2,83	98 3,85	146 5,74	190 7,48	210 8,26	245 9,64
Wt. (kg/lb)			70 154	110 242	250 550	500 1100	880 1936	1620 3564
Catal. no.			80BPS/xx	80CPS/xx	80APS/xx	80GPS/xx	80HPS/xx	80JPS/xx

1) Complete Pressure-Temperature ratings on page 24, 25

### Ratings (ASTM A105)

1500 p.s.i. @ 850°F  
3705 p.s.i. @ 100°F

### Test pressure (ASTM A105)

**Hydraulic: (minimum)**  
Body - 5575 p.s.i.  
Seat - 4100 p.s.i.  
**Air under water:**  
Seat - 85 p.s.i.

### Standards

**Construction** founded on BS 1873  
**Socket weld** ASME B16.11  
**Butt weld** ASME B16.25  
**Test** API 598, BS EN 12266 (Pt. 1)

### Connections (xx)

**SW** Socket weld  
**B4** Butt weld 40  
**B8** Butt weld 80  
**B6** Butt weld 160  
**BX** Butt weld XXS

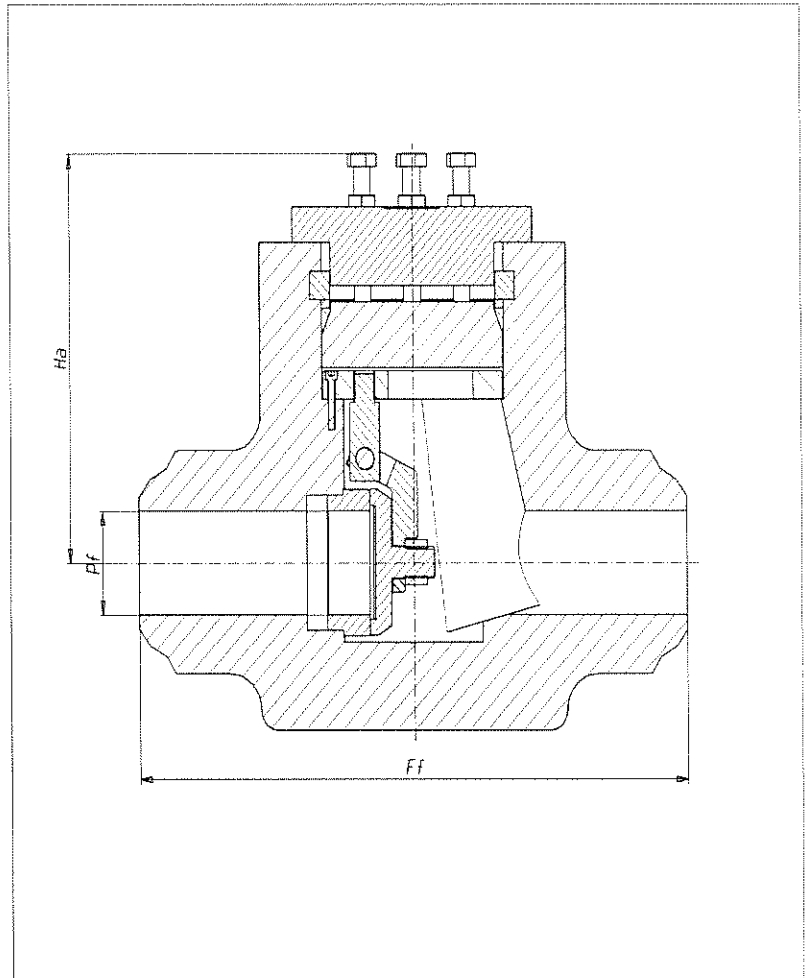

### STANDARD BORE

			3"	4"	6"	8"	10"	12"
<b>Ff (mm/in)</b>			305 12,0	406 15,9	559 22,0	711 27,9	864 34,0	864 34,0
<b>Ha (mm/in)</b>			220 8,66	323 12,7	400 15,7	450 17,7	505 19,8	590 23,2
<b>Pf (mm/in)</b>			72 2,83	98 3,85	146 5,74	190 7,48	210 8,26	245 9,64
<b>Wt. (kg/lb)</b>			70 154	110 242	250 550	500 1100	880 1936	1620 3564
<b>Catal. no.</b>			85BPS/xx	85CPS/xx	85APS/xx	85GPS/xx	85HPS/xx	85JPS/xx

1) Complete Pressure-Temperature ratings on page 24, 25

### Ratings (ASTM A105)

2500 p.s.i. @ 850°F  
6170 p.s.i. @ 100°F

### Test pressure (ASTM A105)

**Hydraulic:** (minimum)  
Body - 9255 p.s.i.  
Seat - 6787 p.s.i.  
**Air under water:**  
Seat - 85 p.s.i.

### Standards

**Construction** founded on BS 1873  
**Socket weld** ASME B16.11  
**Butt weld** ASME B16.25  
**Test** API 598, BS EN 12266 (Pt.1)

### Connections (xx)

**SW** Socket weld  
**B4** Butt weld 40  
**B8** Butt weld 80  
**B6** Butt weld 160  
**BX** Butt weld XXS

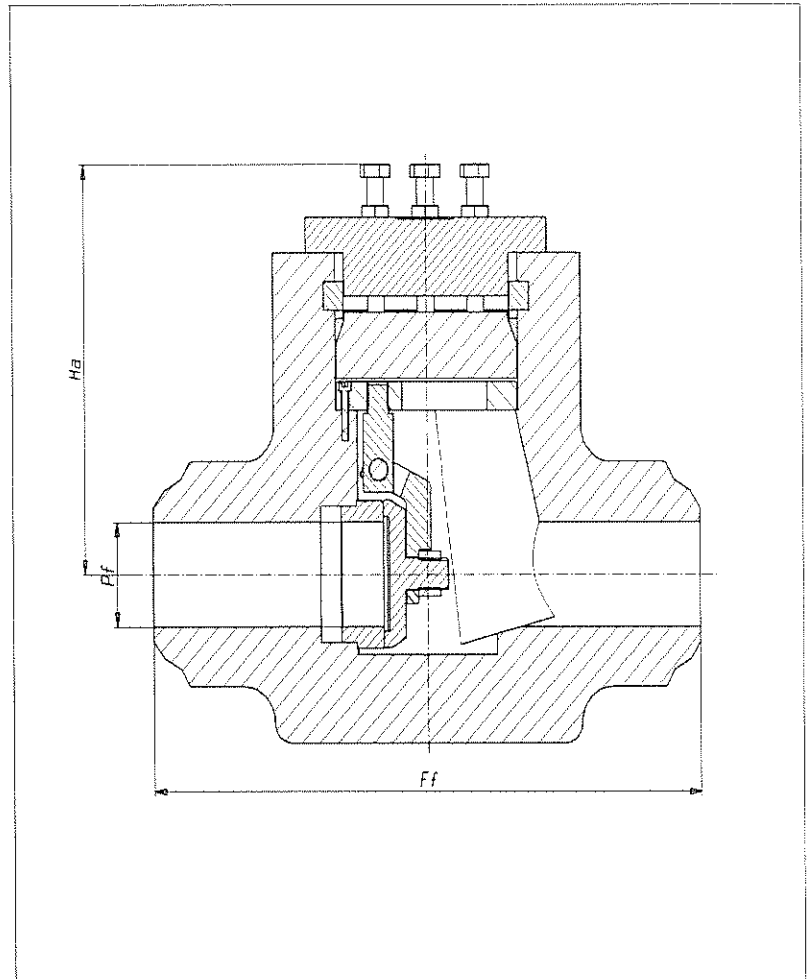

### STANDARD BORE

		3"		4"		6"		8"		10"		12"	
Ff (mm/in)		368	14,4	457	17,9	610	24,0	762	30,0	864	34,0	864	34,0
Ha (mm/in)		276	10,8	290	11,4	380	14,9	486	19,1	500	19,6	600	23,6
Pf (mm/in)		57	2,24	75	2,95	110	4,33	147	5,78	185	7,28	218	8,58
Wt. (kg/lb)		90	198	120	264	300	660	700	1540	850	1870	1300	2860
Catal. no.		215BPS/xx		215CPS/xx		215APS/xx		215GPS/xx		215HPS/xx		215JPS/xx	

1) Complete Pressure-Temperature ratings on page 24, 25

**Wedge**

We have designed a new tee-head connection of the wedge. The wedge is now closed around the stem. Flexible split wedge is standard on our Forged Valves. During the stroke, the contact area between wedge and seat rings is wide.

Standard Flexible

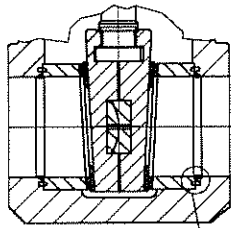

Seatrings are welded in

Upon request

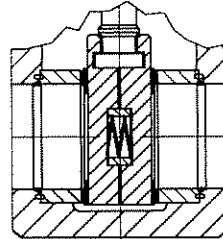

**Bonnet**

Advanced Pressure Seal design is such that the bonnet is easy to be dismantled. The segment ring is kept in the right position by the safety ring.

High tightness is achieved with pure graphite gasket ring, with a F316 jacket on both sides.

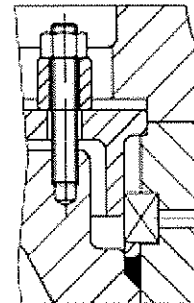

**Packing**

The new design of packing ensures high tightness with pure graphite pressed rings with two braided graphite ring on top and bottom. The new design of pure graphite packing also allows vacuum service and protection against fugitive emissions.

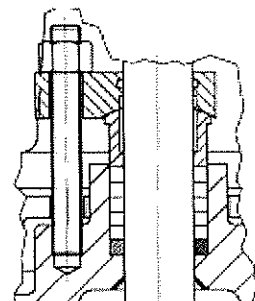

# ***Appendix***

---





# Pressure - Temperature Charts

## ASTM A105 - A350/LF2

F	°C	150	PN20	300	PN50	600	PN100	800	PN130	900	PN150	1500	PN250	2500	PN420	4500	PN760
		psig	bar	psig	bar	psig	bar	psig	bar	psig	bar	psig	bar	psig	bar	psig	bar
100	38	285	19.7	740	51.0	1480	102.1	1975	136.2	2220	153.1	3705	255.5	6170	425.5	11110	766.2
200	93	260	17.9	675	46.6	1350	93.1	1800	124.1	2025	139.7	3375	232.8	5625	387.9	10120	697.9
300	149	230	15.9	655	45.2	1315	90.7	1750	120.7	1970	135.9	3280	226.2	5470	377.2	9845	679.0
400	204	200	13.8	635	43.8	1270	87.6	1690	116.6	1900	131.0	3170	218.6	5280	364.1	9505	655.5
500	260	170	11.7	600	41.4	1200	82.8	1595	110.0	1795	123.8	2995	206.6	4990	344.1	8980	619.3
600	316	140	9.7	550	37.9	1095	75.5	1460	100.7	1640	113.1	2735	188.6	4560	314.5	8210	566.2
650	343	125	8.6	535	36.9	1075	74.1	1430	98.6	1610	111.0	2685	185.2	4475	308.6	8055	555.5
700	371	110	7.6	535	36.9	1065	73.4	1420	97.9	1600	110.3	2665	183.8	4440	306.2	7990	551.0
750	399	95	6.6	505	34.8	1010	69.7	1345	92.8	1510	104.1	2520	173.8	4200	289.7	7560	521.4
800	427	80	5.5	410	28.3	825	56.9	1100	75.9	1235	85.2	2060	142.1	3430	236.6	6170	425.5
850	454	65	4.5	270	18.6	535	36.9	715	49.3	805	55.5	1340	92.4	2230	153.8	4010	276.6
900	482	50	3.4	170	11.7	345	23.8	460	31.7	515	35.5	860	59.3	1430	98.6	2570	177.2
950	510	35	2.4	105	7.2	205	14.1	275	19.0	310	21.4	515	35.5	860	59.3	1545	106.6
1000	538	20	1.4	50	3.4	105	7.2	140	9.7	155	10.7	260	17.9	430	29.7	770	53.1

## ASTM A 182/F11-A182/F12

F	°C	150	PN20	300	PN50	600	PN100	800	PN130	900	PN150	1500	PN250	2500	PN420	4500	PN760
		psig	bar	psig	bar	psig	bar	psig	bar	psig	bar	psig	bar	psig	bar	psig	bar
100	38	290	20	750	51.7	1500	103.4	2000	137.9	2250	155.2	3750	258.6	6250	431.0	11250	775.9
200	93	260	17.93	750	51.7	1500	103.4	2000	137.9	2250	155.2	3750	258.6	6250	431.0	11250	775.9
300	149	230	15.86	720	49.7	1445	99.7	1925	132.8	2165	149.3	3610	249.0	6015	414.8	10830	746.9
400	204	200	13.79	695	47.9	1385	95.5	1850	127.6	2080	143.4	3465	239.0	5775	398.3	10400	717.2
500	260	170	11.72	665	45.9	1330	91.7	1775	122.4	1995	137.6	3325	229.3	5540	382.1	9965	687.2
600	316	140	9.655	605	41.7	1210	83.4	1615	111.4	1815	125.2	3025	208.6	5040	347.6	9070	625.5
650	343	125	8.621	590	40.7	1175	81.0	1570	108.3	1765	121.7	2940	202.8	4905	338.3	8825	608.6
700	371	110	7.586	570	39.3	1135	78.3	1515	104.5	1705	117.6	2840	195.9	4730	326.2	8515	587.2
750	399	95	6.552	530	36.6	1065	73.4	1420	97.9	1595	110.0	2660	183.4	4430	305.5	7970	549.7
800	427	80	5.517	510	35.2	1015	70.0	1355	93.4	1525	105.2	2540	175.2	4230	291.7	7610	524.8
850	454	65	4.483	485	33.4	975	67.2	1300	89.7	1460	100.7	2435	167.9	4060	280.0	7305	503.8
900	482	50	3.448	450	31.0	900	62.1	1200	82.8	1350	93.1	2245	154.8	3745	258.3	6740	464.8
950	510	35	2.414	320	22.1	640	44.1	850	58.6	955	65.9	1595	110.0	2655	183.1	4785	330.0
1000	538	20	1.379	215	14.8	430	29.7	575	39.7	650	44.8	1080	74.5	1800	124.1	3240	223.4
1050	566	20	1.379	145	10.0	290	20.0	385	26.6	430	29.7	720	49.7	1200	82.8	2160	149.0
1100	593	20	1.379	95	6.6	190	13.1	255	17.6	290	20.0	480	33.1	800	55.2	1440	99.3
1150	621	20	1.379	60	4.1	125	8.6	165	11.4	185	12.8	310	21.4	515	35.5	925	63.8
1200	649	15	1.034	40	2.8	75	5.2	100	6.9	115	7.9	190	13.1	315	21.7	565	39.0

For welding and valves only. Flanged end ratings terminate at 1000°F.

A105: permissible, but not recommended for prolonged usage above about 800°F.  
 A350/LF2: not to be used over 650°F.  
 A182/F11-A182/F12: permissible but not recommended for prolonged usage above about 1100°F.



# Pressure - Temperature Charts

## ASTM A182/F22

°F	°C	150	PN20	300	PN50	600	PN100	800	PN130	900	PN150	1500	PN250	2500	PN420	4500	PN760
		psig	bar	psig	bar	psig	bar	psig	bar	psig	bar	psig	bar	psig	bar	psig	bar
100	38	290	20.0	750	51.7	1500	103.4	2000	137.9	2250	155.2	3750	258.6	6250	431.0	11250	775.9
200	93	260	17.9	750	51.7	1500	103.4	2000	137.9	2250	155.2	3750	258.6	6250	431.0	11250	775.9
300	149	230	15.9	730	50.3	1455	100.3	1940	133.8	2185	150.7	3640	251.0	6070	418.6	10925	753.4
400	204	200	13.8	705	48.6	1410	97.2	1880	129.7	2115	145.9	3530	243.4	5880	405.5	10585	730.0
500	260	170	11.7	665	45.9	1330	91.7	1775	122.4	1995	137.6	3325	229.3	5540	382.1	9965	687.2
600	316	140	9.7	605	41.7	1210	83.4	1615	111.4	1815	125.2	3025	208.6	5040	347.6	9070	625.5
650	343	125	8.6	590	40.7	1175	81.0	1570	108.3	1765	121.7	2940	202.8	4905	338.3	8825	608.6
700	371	110	7.6	570	39.3	1135	78.3	1515	104.5	1705	117.6	2840	195.9	4730	326.2	8515	587.2
750	399	95	6.6	530	36.6	1065	73.4	1420	97.9	1595	110.0	2660	183.4	4430	305.5	7970	549.7
800	427	80	5.5	510	35.2	1015	70.0	1355	93.4	1525	105.2	2540	175.2	4230	291.7	7610	524.8
850	454	65	4.5	485	33.4	975	67.2	1300	89.7	1460	100.7	2435	167.9	4060	280.0	7305	503.8
900	482	50	3.4	450	31.0	900	62.1	1200	82.8	1350	93.1	2245	154.8	3745	258.3	6740	464.8
950	510	35	2.4	375	25.9	755	52.1	1005	69.3	1130	77.9	1885	130.0	3145	216.9	5665	390.7
1000	538	20	1.4	260	17.9	520	35.9	695	47.9	780	53.8	1305	90.0	2170	149.7	3910	269.7
1050	566	20	1.4	175	12.1	350	24.1	465	32.1	525	36.2	875	60.3	1455	100.3	2625	181.0
1100	593	20	1.4	110	7.6	220	15.2	295	20.3	330	22.8	550	37.9	915	63.1	1645	113.4
1150	621	20	1.4	70	4.8	135	9.3	180	12.4	205	14.1	345	23.8	570	39.3	1030	71.0
1200	649	20	1.4	40	2.8	80	5.5	110	7.6	125	8.6	205	14.1	345	23.8	615	42.4

## ASTM A182/F91

°F	°C	150	PN20	300	PN50	600	PN100	800	PN130	900	PN150	1500	PN250	2500	PN420	4500	PN760
		psig	bar	psig	bar	psig	bar	psig	bar	psig	bar	psig	bar	psig	bar	psig	bar
100	38	290	20.0	750	51.7	1500	103.4	2000	137.9	2250	155.2	3750	258.6	6250	431.0	11250	775.9
200	93	260	17.9	750	51.7	1500	103.4	2000	137.9	2250	155.2	3750	258.6	6250	431.0	11250	775.9
300	149	230	15.9	730	50.3	1455	100.3	1940	133.8	2185	150.7	3640	251.0	6070	418.6	10925	753.4
400	204	200	13.8	705	48.6	1410	97.2	1880	129.7	2115	145.9	3530	243.4	5880	405.5	10585	730.0
500	260	170	11.7	665	45.9	1330	91.7	1775	122.4	1995	137.6	3325	229.3	5540	382.1	9965	687.2
600	316	140	9.7	605	41.7	1210	83.4	1615	111.4	1815	125.2	3025	208.6	5040	347.6	9070	625.5
650	343	125	8.6	590	40.7	1175	81.0	1570	108.3	1765	121.7	2940	202.8	4905	338.3	8825	608.6
700	371	110	7.6	570	39.3	1135	78.3	1515	104.5	1705	117.6	2840	195.9	4730	326.2	8515	587.2
750	399	95	6.6	530	36.6	1065	73.4	1420	97.9	1595	110.0	2660	183.4	4430	305.5	7970	549.7
800	427	80	5.5	510	35.2	1015	70.0	1355	93.4	1525	105.2	2540	175.2	4230	291.7	7610	524.8
850	454	65	4.5	485	33.4	975	67.2	1300	89.7	1460	100.7	2435	167.9	4060	280.0	7305	503.8
900	482	50	3.4	450	31.0	900	62.1	1200	82.8	1350	93.1	2245	154.8	3745	258.3	6740	464.8
950	510	35	2.4	385	26.6	755	52.1	1025	70.7	1160	80.0	1930	133.1	3220	222.1	5795	399.7
1000	538	20	1.4	365	25.2	725	50.0	968	66.8	1090	75.2	1820	125.5	3030	209.0	5450	375.9
1050	566	20	1.4	360	24.8	720	49.7	960	66.2	1080	74.5	1800	124.1	3000	206.9	5400	372.4
1100	593	20	1.4	300	20.7	605	41.7	805	55.5	905	62.4	1510	104.1	2515	173.4	4525	312.1
1150	621	20	1.4	225	15.5	445	30.7	595	41.0	670	46.2	1115	76.9	1855	127.9	3345	230.7
1200	649	20	1.4	145	10.0	290	20.0	383	26.4	430	29.7	720	49.7	1200	82.8	2160	149.0

For welding and valves only. Flanged end ratings terminate at 1000°F.

ASTM F22: permissible but not recommended for prolonged usage above about 1100°F.



**HEAD OFFICE & FACTORY**

Località Pradaglie – 29013 Carpaneto (PC) – ITALY

Tel. +39 0523 854011 – Fax +39 0523 850389

E-mail: [sales@douglas-chero.com](mailto:sales@douglas-chero.com)

[www.douglas-chero.com](http://www.douglas-chero.com)