

GS 01R06A00-01E-E



Model DY-D, DY-E
Integral Type



Model DY-A
Remote Type Converter



Model DY-N
Remote Type Detector



Model DY/R1
Reduced Bore Type

Based on the field proven technology

By the unique SSP (Spectral Signal Processing)* technology, digitalYEWFLO provides high accuracy and stability, even in harsh process conditions. Combined with high reliability and robust design, it delivers improvements in plant efficiency and reduce operating costs. digitalYEWFLO Multi-Variable Type (option: /MV) with built in temperature sensor, temperature measurement and mass flow calculation is available. digitalYEWFLO Reduced Bore Type (option: /R1) Concentric reduced bore piping diameter integrated in casted construction. digitalYEWFLO Dual Calibration Type (option /DC1, /DC2). Integrated Dual-Sens solution for your safety applications.

* SSP is YOKOGAWA's original technology for digital signal processing.

FEATURES

- New functions with SSP (Spectral Signal Processing) technology:
SSP is built into the powerful electronics of digital YEWFLO. SSP analyses the fluid conditions inside digitalYEWFLO and uses the data to automatically select the optimum adjustment for the application, providing features never before realized in a vortex flowmeter.
SSP accurately senses vortices in the low flow range, providing outstanding flow stability.
- Advanced Self-diagnostics:
The application condition, such as high pipeline vibration and abnormal flow, is predicted and indicated.
- High Accuracy:
±0.75% of Reading (Liquid)
[±0.5% of Reading: Typical Accuracy/Non-Guaranteed]
±1% of Reading (Gas, Steam)
- Wide Process Temperature Range:
High temperature version up to 450 °C

- Simple parameter settings:
Frequently-used selections grouped together in a quick-access format decreases commissioning time.
- Clear, concise indicator:
Simultaneous flow rate or temperature (Option /MV) and total flow rate along with process diagnosis conveniently displayed.
- Dual output for analog / pulse:
Simultaneous output for flow rate or temperature (Option /MV) and pulse.
- Alarm output, status output (Flow switch):
An alarm signal output, in case alarm occurs.
- No moving parts stainless steel detector:
High durable and safe.
- Remote cable length 30 m maximum.
- ATEX / FM flame (explosion) proof / intrinsically safe approval
- Communication function includes *FOUNDATION Fieldbus, BRAIN and *HART protocol.
Refer to GS 01F06F00-01E for Fieldbus communication type when marked with “#”:
* FOUNDATION is a registered trade mark of FOUNDATION Fieldbus.
* HART is a registered trade mark of the HART Communication Foundation.

CONTENTS	
Features	P. 1
Standard Specifications	P. 2
Model- and Suffix-Code	P. 5
Option Spec for General Use	P. 8
Option Spec for Hazardous Use	P. 10
Option Spec for Multi-Variable Type (Option)	P. 12
Option Spec for Reduced Bore type (Option)	P. 13
Option Spec for Dual Calibrated DY (Option)	P. 13
Sizing	P. 15
Remarks on Installation	P. 20
External Dimensions	P. 23
Ordering Instructions	P. 34

MULTI-VARIABLE OPTION (/MV)

- digitalYEWFL0 with built in temperature sensor (Pt1000) in the vortex shedder bar. Temperature measurement and mass flow calculation by temperature is available. (Refer to P.12)
- digitalYEWFL0 with built in steam trend, mass measurement of saturated steam and super heated steam (mass flow calculation)
- Accuracy of digitalYEWFL0 Multi-Variable type is $\pm 0.5\%$ of rate for temperature measurement, $\pm 2\%$ of rate for mass flow calculation (saturated steam).

DUAL CALIBRATED OPTION (/DC1; /DC2)

Dual bolted calibration and disassembly before shipment:

- improves flexibility of installation
- improves safety by redundant installation possibility
- accuracy is equal to single installation

REDUCED BORE OPTION (/R1)

Integrated and casting construction with concentric reduced bore piping:

- reduces installation costs and improves safety: Expansion of measurement range into low flow rate regions
- reduces costs for easy replacement: The same face-to-face dimension as standard type.

STANDARD SPECIFICATIONS

Performance Specifications

Fluid to be Measured:

Liquid, Gas, Steam (Avoid Multiphase Flow and Sticky Fluids)

Measuring Flow Rates: Refer to Table 6 - 10

Accuracy: $\pm 0.75\%$ of Reading (Liquid)
 $\pm 1\%$ of Reading (Gas, Steam)
 Refer to page 16

Repeatability: $\pm 0.2\%$ of Reading

Calibration:

This flowmeter is factory-calibrated using a water flow facility.
 Temperature measurement test and flow calibration by water flow when Multi-Variable Type is selected.

Normal Operating Condition

For hazardous area applications the limitations in "Option Spec for Hazardous Use" page 10 - 11 apply.

Process Temperature Range:

-29 to 250 °C (general)
 -29 to 450 °C (High Process Temperature Version: option /HT)
 When Multi-Variable type is selected, refer to P.12
 Refer to Figure 1 for integral converter type.

Process Pressure Limit:

-0.1MPa (-1 bar) to flange rating.

Ambient Temperature Range:

- 29 to 85 °C (Remote type detector)
- 40 to 85 °C (Remote type converter)
- 29 to 85 °C (Integral type, refer to Figure 1)
- 29 to 80 °C (Integral type with Indicator, refer to Figure 1)
- 30 to 80 °C (Remote type converter with Indicator)

Ambient Humidity : 5 to 100% RH (at 40 °C)
 (No Condensation)

Power Supply Voltage (#):

- 10.5 to 42 V DC
 - 10.5 to 30 V DC (Lightning Protector: option)
- (Refer to Figure 2 ; Relationship Between Power Supply Voltage and Load Resistance)

Mechanical Specifications

Material (General Type):

Refer to Table 1:

Body/Flanges:

- CF8M casting stainless steel (equiv. 1.4408)
- WCB casting carbon steel ASTM-A216WCB
- CW-12MW (equiv. Hastelloy C276) on demand only

Hastelloy is a registered trademark of Haynes International Inc.

Shedder bar:

- 1.4462 duplex stainless steel (DY015)
- 1.4517 duplex stainless steel
- CW-12MW (equiv. Hastelloy C276)

Gasket:

- refer to table 1

Non-Wetted Parts:

Housing (Case, Cover):

Aluminum alloy JIS ADC12

Name Plate: Stainless steel JIS SUS304

DYA Mounting Bracket for 2" pipe :

Stainless Steel 304/1.4301

Coating Color:

Converter case, cover: Deep sea moss green (Munsell 0.6GY 3.1/2.0) (Polyurethane corrosion-resistant coating)

Degree of Protection:

IP66/IP67 (IEC 60529), Type 4X (NEMA 250)

Hazardous Area Classifications (#):

Refer to item "Option Spec for Hazardous Use"

Electrical Connection:

ANSI 1/2 NPT female,
 ISO M20 x 1.5 female

Signal Cable:

Model DYC cable, used for remote detector and converter.

Max. length: 30 m.

Outer Sheath Material: Heat resisting polyethylene

Durable Temperature: -40 to 150 °C

Weight:

Refer to item "External Dimensions"

Mounting:

Integral type or Remote type detector:

Flange mounting or wafer mounting by flange adjacent to the pipeline.

Remote type converter: 2 inch pipe mounting.

Electrical Specifications

** : Pulse output, alarm output and status output use the common terminal, therefore these functions are not used simultaneously.

Output Signal (#): Dual output (both analog and transistor contact output can be obtained simultaneously). In this case refer to the item "Remarks on installation" for power supply and pulse output wiring.

Analog: 4 to 20 mA DC, 2-wire system.

Transistor Contact Output**:

Open collector, 3-wire system.

Pulse, alarm, status output are selected by parameter setting.

Contact rating: 10.5 to 30 V DC, 120 mA DC*1

Low level: 0 to 2 V DC. (refer to Figure3)

*1: 10.5 to 30 V DC. 80 mA DC for ATEX Intrinsically Safe Approval (/KS2)

Communication Requirement:

Communication Signal (#):

BRAIN or HART communication signal (superimposed on a 4 to 20 mA DC signal)

Conditions of Communication Line:

Load Resistance:

250 to 600 Ω (including cable resistance).

Refer to Figure 2.

Supply Voltage:

16.4 to 42 V DC for digital communications BRAIN and HART protocols (16.4 to 30 V DC for intrinsically safe type).

Refer to Figure 2.

Distances to other Power Line: 15 cm or more (Parallel wiring should be avoided.)

BRAIN:

Communication Distance:

Up to 2 km, when polyethylene insulated PVC-sheathed cables (CEV cables) are used. Communication distance varies depending on type of cable used and wiring.

Load Capacitance: 0.22 μ F or less

Load Inductance: 3.3 mH or less

Input Impedance of communicating device:

10 k Ω or more at 2.4 kHz

Selection of HART 5 / HART 7

Output signal code		-J	
Ordering information		Specify „5“	Specify „7“
HART Protocol Revision		HART 5	HART 7
Selection guide	Requirement for HART 7 functionality	No	YES Be sure to confirm the protocol revision of the HART configuration tool shown in *1
	Other conditions	Available to switch to HART 7 protocol after delivery by user-configuration	----
Remarks		*1	*1

*1 HART protocol revision for the device and HART configuration tool HART7 communication is supported by FieldMate R2.02 or later.

Parameter will be programmed according HART 5, then switched to HART 7.

HART protocol revision and availability:

	Protocol revision supported by HART configuration tool	
	5	7
DY or DYA HART 5	Available	Available
DY or DYA HART 7	Not Available	Available

Note: Protocol revision supported by HART configuration tool must be the same or higher than that of the digital YEWFL0.

Functions:

Damping Time Constant:

0 to 99 s (63 % response time)

Note: Delay time is 0.5 s

Analog output circuit time constant is 0.3 s

Pulse Output Function**:

Pulse output is selected from scaled pulse, unscaled pulse, frequency (number of pulses output per second at 100% of output).

Pulse frequency: Max 10 kHz

Duty cycles: Approx. 50 % (1:2 to 2:1)

Self -diagnostics and Alarm Output**:

In case alarm occurs (over range output signal, EEPROM error, vibration noise, abnormal conditions such as clogging or bubbles), an alarm signal is output and is indicated.

The alarm signal output goes from close (ON) to open (OFF) during alarming.

Analog Output Function:

Analog output is selected from flow rate and temperature value when option code /MV is selected.

Status Output Function**:

Flow Switch:

In case flow rate decreases under the flow set value, a status signal is output.

Status signal output mode can reverse (ON/OFF) .

Data Security During Power Failure:

Data (parameter, totalizer value, etc.) storage by EEPROM. No back-up battery required.

Correction:

Instrument Error Correction:

Vortex flow meter instrument errors can be corrected by segment approximations.

Reynolds Number Correction:

Output error at Reynolds number 20000 or less is corrected by using five-break-point line-segment approximation.

Gas Expansion Correction:

When measuring a compressible gas and steam, this expansion factor is useful to correct the error at high velocity of flow (35 m/s or more).

Down-scale or Up-scale burn out:

In case a CPU or EEPROM failure occurs, flow meter output signal is set to Up-scale (21.6 mA or more).

Up-scale or Down-scale (3.6 mA or less) is user-selectable through the fail mode alarm jumper.

Indicator:

Flow rate (% or engineering units) or temperature value and totalizer can be indicated simultaneously.

Short message for self diagnostics indicated. Local parameter setting can be operated by key switches.

In mounting direction, the indicator is rotatable 90° to the left or to the right.

EMC Conformity Standards:

EN61326-1 Class A, Table 2 (for use in industrial locations), EN61326-2-3

Note 1: This instrument is a class A product, and it is designed for use in the industrial environment. Please use this instrument in the industrial environment only.

Note 2: Use the metal conduit for the remote cable.

Pressure Equipment Directive:

Notified Body Identification Number 0038

Type of equipment: piping

Type of fluid: liquid and gas

Group of fluid: 1 and 2

Module: H

Model	DN (mm)*	PS (MPa)*	PS x DN	Category **
DY015	15	42	630	Article 3 *** Paragraph 3
DY025	25	42	1050	Article 3 *** Paragraph 3
DY040	40	42	1680	II
DY050	50	42	2100	II
DY080	80	42	3360	II
DY100	100	42	4200	II
DY150	150	42	6300	III
DY200	200	42	8400	III

* PS: Maximum allowable pressure for Flow tube,

DN: Nominal size

** Referred to Table 6 covered by ANNEX II of EC Directive 97/23/EC, Pressure Equipment Directive PED

*** DY015 and DY025 are not regulated by PED.

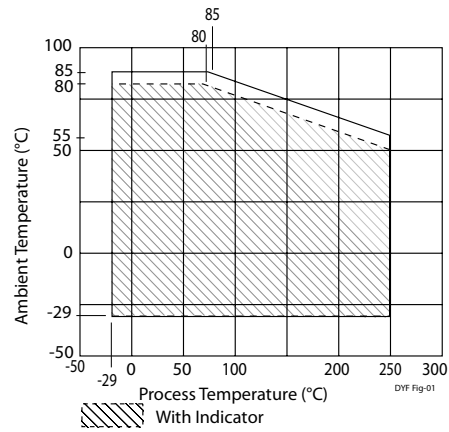


Figure 1 Ambient Temperature limit (Integral Type)

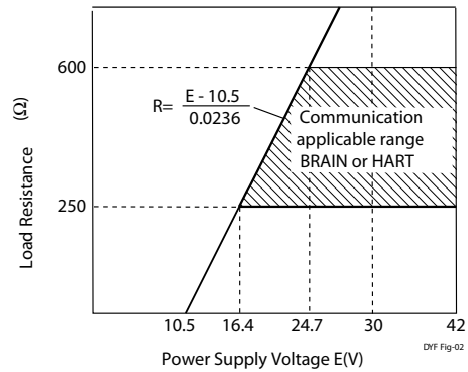


Figure 2 Relationship between Power Supply and Load Resistance

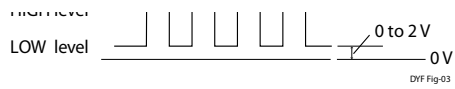


Figure 3 High and low level (Pulse output)

Model and Suffix Codes

DY Vortex Flowmeter (Integral Type, Remote Type Detector)

Model	Suffix Code	Description
DY015		Size 15 mm (½ inch)
DY025		Size 25 mm (1 inch)
DY040		Size 40 mm (1½ inch)
DY050		Size 50 mm (2 inch)
DY080		Size 80 mm (3 inch)
DY100		Size 100 mm (4 inch)
DY150		Size 150 mm (6 inch)
DY200		Size 200 mm (8 inch)
Output signal / Communication *1*11	-D -J -F -N	4 to 20 mA DC, Pulse, BRAIN communication 4 to 20 mA DC, Pulse, HART 7/HART 5 communication Digital communication (Foundation Fieldbus protocol) Remote type detector
Body material *2*13	B G W X	Stainless steel (CF8M / equiv. 1.4408) Stainless steel (1.4552) Carbon steel (WCB / equiv. A216 WCB) *14 Others
Shedder bar material *3*13	B L X	CF8M Stainless Steel for DY150 /NC or /HT and DY200 /NC or /HT Duplex Stainless Steel Others
Process connection *4*15	AA1 AA2 AA4 AD2 AD4 BA1 BA2 BA4 BA5 BD1 BD2 BD3 BD4 BD5 BD6 BD7 CA4 CA5	ANSI Class 150 Wafer ANSI Class 300 Wafer ANSI Class 600 Wafer DIN PN16 Wafer DIN PN40 Wafer ANSI Class 150 Flange (RF) ANSI Class 300 Flange (RF) ANSI Class 600 Flange (RF) ANSI Class 900 Flange (RF) DIN PN10 Flange (RF) DIN PN16 Flange (RF) DIN PN25 Flange (RF) DIN PN40 Flange (RF) DIN PN64 Flange (RF) DIN PN100 Flange (RF) DIN PN160 Flange (RF) ANSI Class 600 Flange (RJ) ANSI Class 900 Flange (RJ)
RF: Raised Face RJ: Ring Joint		
Electrical connection *10	-2 -4	ANSI ½ NPT Female *5 ISO M20 x 1.5 Female
Indicator *6	D N	With Indicator None Indicator, Remote type detector
Options	/□ /MV	Refer to Option Specification Multivariable *12

DYA Vortex Flowmeter Converter (Remote type)

Model	Suffix Code	Description
DYA		Vortex Flowmeter Converter (Remote Type)
Output signal / Communication *1	-D -J -F	4 to 20 mA DC, Pulse, BRAIN communication 4 to 20 mA DC, Pulse, HART7/HART5 communication Digital communication (Foundation Fieldbus protocol) *11
Electrical connection *10	2 4	ANSI ½ NPT Female *5 ISO M20 x 1.5 Female
Indicator	D N	With Indicator None Indicator
Options	/□ /MV	Refer to Option Spec Multivariable *12

DYC Signal Cable

Model	Suffix Code	Description
DYC		Signal Cable
Cable End	-0 -1	Without End Finish *7 With End Finish
Cable length	-05 -10 -15 -20 -25 -30 □□□	5 m 10 m 15 m 20 m 25 m 30 m □□ m *8
Options	/C □ /MV	Cable End Finish Parts *9 Multivariable *12

- * 1: Nominal size, Fluid (Liquid, Gas, Steam), Density, Viscosity, Pressure, Temperature, Flow range, Parameters are set at the factory before shipment.
- * 2: Refer to table 1 (page 6)
In case of /NC or /HY or /HT select X for CF8M or W for WCB.
- * 3: Refer to table 1.
In case of /NC or /HY or /HT, select X (others).
- * 4: Refer to Table 2.
- * 5: In case of /FF1, the screw length is deeper than ANSI standard for 0.5 to 3.5 threads.
- * 6: Indicator is not available for remote type detector.
- * 7: One set of end finish part is attached.
- * 8: Fill in two digit figure per 5 m unit (e.g. 35 m or 95 m etc.). The cable can be cut to required length at customer site, max. cable length between detector and converter within 30 m. In this case, select Cable End Code [-0].
- * 9: An entered digit figure shows required set quantity. Only for Cable End Code [-0]
- * 10: In case of an explosion protect type, it depends for an electrical connection on the kind of an explosion protect type. Refer to "Option Spec for Hazardous use"
- * 11: For FOUNDATION Fieldbus protocol, refer to GS 01F06F01-01E. For Fieldbus communication type, there are no setting keys on the display board.
- * 12: Essentially, DY- /MV and DY-N***/MV should be combined.
- * 13: Users must consider the characteristics of selected wetted parts material and the influence of process fluids. The use of inappropriate materials can result in the leakage of corrosive process fluids and cause injury to personnel and/or damage to plant facilities. It is also possible that the instrument itself can be damaged and that fragments from the instrument can contaminate the user's process fluids.
Be very careful with highly corrosive process fluids such as hydrochloric acid, sulfuric acid, hydrogen sulfide, sodium hypochlorite, and high-temperature steam (150 °C [302 °F] or above). Contact Yokogawa for detailed information of the wetted parts material.
- * 14: Body material carbon steel (WCB): Due to wet calibration DY will always generate superficial rust in the flow path and on the surface during shipping to customer site. The superficial oxidation has no influence on the accuracy of the flowmeter. Unfortunately the oxidation can not be avoided with carbon steel body material.
- * 15: For process connection BD: Flanges with hole pattern, flange diameter, flange facing according EN 1092-1 can be used. Standard surface Ra 3.2 - 6.3. For process connection BA: Flanges with hole pattern, flange diameter, flange facing according ASME B16.5 can be used.

Table 1 Body, Shedder bar, Gasket Material

Body Material		Model code letter	Standard (Note 1)	Model code letter	Anti-corrosion version II (/HY) (Note 1 + 2)	Model code letter	High process temperature version (/HT) (Note 1 + 2)	Model code letter	NACE Material (/NC)
Model (Note 3)									
DY015	DY025/R1	B	ASTM CF8M	X	ASTM CF8M (Note 2)	--	--	X	ASTM CF8M
DY025	DY040/R1					X	ASTM CF8M		
DY040	DY050/R1								
DY050	DY080/R1								
DY080	DY100/R1	B	ASTM CF8M	X	ASTM CF8M	X	ASTM CF8M	X	ASTM CF8M
DY100	DY150/R1	W	A216 WCB	W	A216 WCB	W	A216 WCB	W	A216 WCB
DY150	DY200/R1								
DY200	--								

(Note 1) In case body material is carbon steel (A216 WCB) the following is not available: process connection AA[] or AD[] (wafer type) or reducer type /R1

(Note 2) In case of /NC, /HY or /HT

select for stainless steel body (CF8M) model code letter "X,"

select for carbon steel body (WCB) model code letter "W,"

select shedder bar according to shedder bar material table below

(Note 3) Reduced bore type is flange type only, see also table 2 for further detail.

Shedder bar material		Model code letter	Standard	Model code letter	Anti-corrosion version II (/HY) (Note 1)	Model code letter	High process temperature version (/HT) (Note 1)	Model code letter	NACE Material (/NC) (Note 1)	
Model (Note 2)										
DY015	DY025/R1	L	EN 1.4462	X	ASTM N 10276	--	--	X	ASTM N 10276	
DY025	DY040/R1	L	EN 1.4517	X	ASTM CW-12MW (Note 4)	X	ASTM CW-12MW	X	ASTM CW-12MW	
DY040	DY050/R1									
DY050	DY080/R1									
DY080	DY100/R1									
DY100	DY150/R1									
DY150	DY200/R1									
DY200	--					X	ASTM CW-12MW	X	ASTM CW-12MW	
						B	ASTM CF8M (Note 3)	B	ASTM CF8M (Note 3)	

(Note 1) In case of /NC, /HY or /HT

select for stainless steel body (CF8M) model code letter "X,"

select for carbon steel body (WCB) model code letter "W,"

select shedder bar according to shedder bar material table above

(Note 2) /MV shedder bar material is EN 1.4517 only, available from size DY025/MV to DY200/MV

(Note 3) Shedder bar code [X] or [B] is selectable for DY150/HT, DY150/NC, DY200/HT and DY200/NC

(Note 4) /HY not possible for DY150/R1

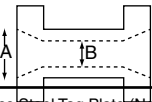
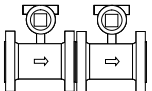
Gasket material		Standard	Anti-corrosion version II (/HY)	High process temperature version (/HT)	NACE Material (/NC)
Model					
DY015	DY025/R1	JIS SUS316 stainless steel with polytetrafluoroethylene (Teflon) coating	JIS SUS316 stainless steel with polytetrafluoroethylene (Teflon) coating	--	JIS SUS316 stainless steel with polytetrafluoroethylene (Teflon) coating
DY025	DY040/R1				
DY040	DY050/R1				
DY050	DY080/R1				
DY080	DY100/R1				
DY100	DY150/R1				
DY150	DY200/R1				
DY200	--				
				JIS SUS316 stainless steel plated with silver	

Table 2 Flowmeter Selection Guide for Sizes, Process Connections and Body Materials

Process Connection Rating	Process connection	Model Code	DY015		DY025		DY040		DY050		DY080		DY100		DY150		DY200	
				/R1		/R1		/R1		/R1		/R1		/R1		/R1		/R1
ANSI Class 150	wafer	AA1	B	B			B		B		B		B					
	flange RF	BA1	B	B	B	B	B	B	B	B	B,W	B	B,W	B	B,W	B	B,W	B
ANSI Class 300	wafer	AA2	B	B			B		B		B		B					
	flange RF	BA2	B	B	B	B	B	B	B	B	B,W	B	B,W	B	B,W	B	B,W	B
ANSI Class 600	wafer	AA4	B	B			B		B		B		B					
	flange RF	BA4	B	B			B		B		B,W		B,W		B			
	flange RJ	CA4	B	B			B		B		B		B		B			
ANSI Class 900	flange RF	BA5	B	B			B		B		B		B					
	flange RJ	CA5	B	B			B		B		B		B					
PN 10	flange RF	BD1															B,W	B
PN 16	wafer	AD2											B					
	flange RF	BD2									B,W	B	B,W	B	B,W	B	B,W	B
PN 25	flange RF	BD3															B,W	B
PN 40	wafer	AD4	B	B			B		B		B		B					
	flange RF	BD4	B	B	B	B	B	B	B	B	B,W	B	B,W	B	B,W	B	B,W	B
PN 64	flange RF	BD5							B		B,W		B,W		B,W			
PN 100	flange RF	BD6	B	B			B		B		B,W		B,W		B,W			
PN 160	flange RF	BD7	B	B			B		B		B		B					

- For body material and process connection codes please refer to Model and Suffix Code Table
- ANSI standardized types are worked by serration finishing.
- Refer to "OPTION REDUCED BORE TYPE (/R1)" (P.13), when you select reduced bore type (/R1).

OPTION SPEC FOR GENERAL USE

Item	Specification	Applicable model	Code
Multi Variable Type (Note 5)	Built in Temperature sensor (Pt1000) in vortex shedder bar	DY/DYA	MV
Reduced bore type (Note 7) See P.13 	Integrated and welded construction with concentric reduced bore piping. R1 : Detector size (B) is one meter body size down of digitalYEWFLOW to flange pipe size (A). e.g. DY080/R1 A = 080mm (3") B = 050mm (2")	DY	R1
Stainless Steel Tag Plate (Note 1)	SUS304 tag plate, hung on converter case	DY/DYA	SCT
Stainless Steel Bolt & Nut Assembly	SUS304 bolt/nut assembly. Used when a wafer type is installed.	DY Water type	BL
Hydrostatic / Pneumatic Test Certificate (Note 12)	Test pressure value is in accordance with Table 4. Test time: 10 min. Available for the general type. Test medium: Air, Nitrogen or Water.	DY	T01
Calibration Certificate	Level 2 Declaration and Calibration Equipment List	DY/DYA	L2
	Level 3 Declaration and Primary Standard List	DY/DYA	L3
	Level 4 Declaration and YOKOGAWA Measuring Instruments Control System	DY/DYA	L4
Degrease Treatment ASTM (Note 2)	Degreasing Treatment of wetted surfaces acc. ASTM.	DY	DEG
Epoxy Coating	Epoxy coating for meter cover and case.	DY/DYA	X1
Piling up coating to keep off corrosion	Epoxy and Polyurethane coating for the purpose of corrosion - proof improvement; salt damage, alkali, climate and acidity	DY/DYA	X2
High Process Temperature Version	This specification temperature is from -29 to +450 °C Refer to Table 1 and figure 4 (page 14) Refer to Table 5 for minimum velocity.	DY***-N	HT
NACE material (Note 8)	Metallic wetted parts material compliance with NACE (MR0175) Refer to Table 1	DY	NC
Anti-corrosion Version II	Anti-corrosion Version II. Refer to Table 1. (excluding DY150/R1)	DY	HY
Compliance with NAMUR (Note 6)	Compliance with NAMUR 43. Current signal for measurement is 4 mA up to 20.5 mA. Set output 3.6 mA or less when burn-out occurred.	DY/DYA	NM
ESD compliance according Namur (Note 10)	Internal protection covers for ESD enhancement	DY/DYA	ESD
Down-scale burn-out in CPU or EEPROM failure (Note 3)	Current signal for measurement is 4 mA up to 21.6 mA. Sets the output to 3.6 mA or less when burn-out occurred.	DY***-D,E/ DYA	C1
Lightning Protector	There is an arrester inside converter for power supply line. Maximum power supply voltage: 30 V DC	DY***-D,E/ DYA	A
Stainless Steel Bracket for Remote Converter (DYA)	The bracket material for remote converter type (DYA) is SUS304.	DYA	SB
Converter Installing Direction 180° Change (Note 4)	Converter installing direction 180° change inversely when shipped.	DY	CRC
Smooth flange finish (Note 11) (Note 18)	Finish of flange facing Ra 3.2 ... 6.3. Refer to Figure 6.	DY	ASF
Rough DIN Flange (Note 21)	Finish of DIN Flange Ra 6.3 ... 25 acc. DIN 2526 Type C	DY	DFC
Smooth DIN Flange (Note 21)	Finish of DIN Flange Ra 0.8 ... 1.6 acc. DIN 2526 Type E	DY	DFE
Groove DIN flange (Note 21)	Flange with groove according to DIN 2512 Type N	DY	DSN
Dual Vortex Calibration (bolted type) (Note 14, 15, 16, 17, 19) See also table on page 13. 	Upstream instrument of the Dual Vortex Calibration is performed assembled with downstream instrument Dual Vortex Calibration certificate is issued instead of the standard calibration certificate Packing of the Vortex is done disassembled as single units Bolts, nuts and gaskets for assembly at site are customer responsibility	DY	DC1
	Downstream instrument of the Dual Vortex Calibration is performed assembled with upstream instrument Dual Vortex Calibration certificate is issued instead of the standard calibration certificate Packing of the Vortex is done disassembled as single units Bolts, nuts and gaskets for assembly at site are customer responsibility	DY	DC2

OPTION SPEC FOR GENERAL USE continued

Item	Specification	Applicable model	Code
Material certificates: Mill sheets (Note 13)	Each certificate to be attached produced by the vendors.	DY	
	Item to be specified		M01
	1. Meterbody		M02
	1. Meterbody, 2. Shedder bar		M03
	1. Meterbody, 2. Shedder bar, 3. Bottom plug		M04
	1. Meterbody, 2. Shedder bar, 3. Bottom plug, 4. Welding rod		
Material certificates: 3.1	3.1 certificate which is attached according to EN10204. Each certificate which is attached produced by the vendors	DY	
	Item to be specified		E01
	1. Meterbody		E02
	1. Meterbody, 2. Shedder bar		E03
	1. Meterbody, 2. Shedder bar, 3. Bottom plug		E04
	1. Meterbody, 2. Shedder bar, 3. Bottom plug, 4. Welding rod		
PAMI test certificate	Positive Material Identification certificate to be attached for the main 3 chemical components of specified materials. Each certificate to be attached.	DY	
	Item to be specified		PM1
	1. Meterbody		PM2
	1. Meterbody, 2. Shedder bar		
DIN EN welding documents submission	1. Welder/Welding Operator Performance Qualification (or Welder Qualification Record) 2. Welding Procedure Specification (WPS) 3. Procedure Qualification Record (PQR) Each certificate to be attached. The customer's name and job name to be specified when ordered.	DY	WP
	Item to be specified		
Dye Penetrant test certificate	Item to be specified	DY	PT
Final product certificate (Note 9)	- Final Product Certificates (FPC) acc. to EN 10204:2004 - Certificate of marking transfer - material Certificates acc. DIN EN 10204:2004 – 3.1 for all materials of body, shedder bar, plug and plate and welding rod. - Test Report acc. to DIN EN 10204:2004 - 2.2 - WQC, WPS, PQR for plug welding - Inspection Report to Dye-Penetration-Test for plug welding (e.g. /PT)	DY	FPC

- (Note 1) When /SCT is not chosen, the specified Tag Number is engraved on the data plate.
When /SCT is chosen, the specified Tag Number is engraved on the data plate and stainless tag plate. The limitation of characters for Tag Number on name plate and stainless steel tag plate: 16 characters (see page 34).
- (Note 2) Due to the DY design small amounts of the alkaline cleaning solution could remain in the flow tube.
- (Note 3) The output is set to 3.6mA or less (General type is set to 21.6mA or more at shipping).
- (Note 4) When /CRC is chosen, the electrical connection is turned to a downstream side.
- (Note 5) Refer to "OPTION SPEC. FOR MULTI-VARIABLE TYPE (MV)" (p.12). In case of Remote type detector (DY***-N), select "/MV" both DY and DYA.
- (Note 6) /NM can not be combined with Remote type detector (DY***-N).
- (Note 7) • High process temperature version (/HT) and Multi-variable type (/MV) for DY025/R1 is not available.
• Flange type only and available process connections are ANSI150, 300 (BA1,BA2), DIN PN 10 - DIN PN40 (BD1 - BD4), see table 2.
• Flange piping size (A) means "DY***-" nominal size.
- (Note 8) Applicability and limitations for the usage of wetted part materials are according to NACE-MR0175
- (Note 9) Accumulation of options /E04, /WP, /PT
- (Note 10) Option /ESD is not possible / not necessary for units without display or with Foundation Fieldbus Communication.
- (Note 11) Only available for DY015 to DY100 with AA1, AA2, AA4 and DY015 to DY200 with BA1, BA2, BA4, BA5.
- (Note 12) In the Test report is the confirmation ("OK") about the pressure test which was done with positive result.
- (Note 13) Certificates may be substituted by Material Certificates acc. EN 10204-3.1, depending on material supplier.
- (Note 14) Not available: DY with wafer, DY with option /R1 and DY150 -CA4
- (Note 15) For-Dual Vortex in bidirectional use please contact your Yokogawa sales office.
- (Note 16) Pressure test is performed separately for upstream and for downstream unit.
- (Note 17) Applicable maximum flow velocity (liquid) is 5,5 m/s with specified accuracy. Proven by standard calibration certificate (media water). Higher flow velocities may result in lower accuracy.
- (Note 18) Option /ASF not available for the following process connections: BA4 with /R*, CA4 with /R*
- (Note 19) For use with reducer types please contact your Yokogawa Sales Office.
- (Note 21) Only valid for flanges BD1 to BD7

OPTION SPEC FOR HAZARDOUS USE

Item	Specification	Code
ATEX	<p>ATEX Flameproof Approval Applicable Standard: EN 60079-0, EN 60079-1 Type of Protection: IIC G Ex d IIC T6...1 Gb (Integral Type Vortex Flowmeter and Remote Type Vortex Flow Detector) IIC G Ex d IIC T6 Gb (Remote Type Vortex Flow Converter) Groups: II, Category: 2 G Temperature Class: T6...T1 (Integral Type Vortex Flowmeter and Remote Type Vortex Flow Detector) T6 (Remote Type Vortex Flow Converter) Process Temp.: T6 (-29 to 80°C), T5 (-29 to 100°C), T4 (-29 to 135°C), T3 (-29 to 200°C), T2 (-29 to 300°C) T1 (-29 to 450°C) (Use /HT version above 250°C), Ambient temperature: -29 to 60°C (Integral Type Vortex Flowmeter and Remote Type Vortex Flow Detector) -40 to 60°C (Remote Type Vortex Flow Converter without indicator) -30 to 60°C (Remote Type Vortex Flow Converter with indicator) Ambient Humidity: 0 to 100%RH (No condensation) Electrical Connection: ANSI 1/2NPT female, ISO M20 x 1.5 female</p>	KF2
	<p>ATEX Intrinsically Safe (Note 2) Applicable Standard : EN 60079-0, EN60079-11, EN 60079-26 Type of protection: Ex ia IIC T4...T1Ga (Integral Type Vortex Flowmeter) Ex ia IIC T6...T1 Ga (Remote Type Vortex Flow Detector) Ex ia IIC T4 Ga (Remote Type Vortex Flow Converter) Groups/Category: II 1 G Temperature Class: T4...T1 (Integral Type Vortex Flowmeter) T6...T1 (Remote Type Vortex Flow Detector) T4 (Remote Type Vortex Flow Converter) Ambient temperature: -29 to +60°C (Integral Type Vortex Flowmeter) -40 to +80[79]°C (Remote Type Vortex Flow Detector) (Option /LT below -29°C, [] for Option /MV at T6) -40 to +80°C (Remote Type Vortex Flow Converter without indicator): -30 to +80°C (Remote Type Vortex Flow Converter with indicator): Ambient Humidity: 5 to 100%RH (No condensation) Process temperature: T6: -196 to 84[79]°C, T5: -196 to 100°C, T4: -196 to 135°C, T3: -196 to 199°C, T2: -196 to 299[289]°C, T1: -196 to 449[439]°C (Option /HT above 250°C and Option /LT below -29°C, [] : Option /MV) Signal/Supply (Terminals SUPPLY + and -) and Pulse (Terminals PULSE + and -) Circuit: Ui = 30 V, Ii = 300 mA, Pi = 0.9 W (linear source), Ci = 14 nF, Li = 0 mH Electrical connection: ANSI 1/2 NPT female, ISO M20 x 1.5 female</p>	KS2
Factory Mutual (FM)	<p>FM Explosion proof Approval Applicable Standard: FM3600, FM3611, FM3615, FM3810, ANSI/NEMA 250 Type of Protection: Explosion proof for Class I, Division 1, Groups A, B, C and D; Dust-ignitionproof Class II/III, Division 1, Groups E, F, and G. "SEAL ALL CONDUITS WITHIN 18 INCHES." "WHEN INSTALLED IN DIV.2, SEALS NOT REQUIRED." Enclosure Rating: Type 4X Temperature Code: T6 Ambient Temperature: -29 to 60°C (Integral Type Vortex Flowmeter and Remote Type Vortex Flow Detector) -40 to 60°C (Remote Type Vortex Flow Converter) Ambient Humidity: 0 to 100%RH (No condensation) Coating of Enclosure: Epoxy resin coating or Polyurethane resin coating. Electrical Connection: ANSI 1/2NPT female</p>	FF1
	<p>FM Intrinsically safe Approval (Note 1) Applicable Standard: FM3600, FM3610, FM3611, FM3810, NEMA-250, ANSI/ISA-60079-0, ANSI/ISA 60079-11 Type of Protection: Intrinsically safe: Class I, Division 1, Groups A, B, C and D, T4 Class II, Division 1, Groups E, F and G, T4 Class III, Division 1, T4 Class I, Zone 0, AEx ia IIC T4 Nonincendive: Class I, Division 2, Groups A, B, C and D, T4 Class II, Division 2, Groups F and G, T4 Class III, Division 1, T4 Ambient Temperature: -29 to +60°C (Integral Type Vortex Flowmeter) -29 to +80°C (Remote Type Vortex Flow Detector) -40 to +60°C (Remote Type Vortex Flow Converter) Ambient Humidity: 0 to 100% RH (No condensation) Indoors and Outdoors: Type 4X Electrical Parameter: Vmax=30Vdc, Imax=165mAdc, Pi=0.9W, Ci=12nF, Li=0.15mH Electrical Connection: ANSI 1/2NPT female</p>	FS1

(Note 1) For intrinsically safe approval, use the barrier certified by the testing laboratories (BARD-400 is not applicable).

OPTION SPEC FOR MULTI-VARIABLE TYPE (/MV) (Note 1)

This options is the same as standard specification except the following items.

		Multi-variable Type					Standard Type
Size	Wafer Type	25mm to 100mm					15mm to 100mm
	Flange Type	25mm to 200mm					15mm to 200mm
Function		Only for indication and output	Mass flow calculation (Volumetric flowrate at standard condition for GAS)				----
Fluid	Type	Liquid, Gas, Saturated steam, Superheated steam	Saturated steam	Superheated steam	Gas	Liquid	Liquid, Gas, Saturated steam, Superheated steam
	Selectable Flow unit	----	kg, t, lb, klb	kg, t, lb, klb	Nm ³ , kNm ³ , MNm ³ , NI, Sm ³ , kSm ³ , MSm ³ , Sl, Scf, kscf, Mscf, N: Normal S: Standard	kg, t, lb, klb	----
Temperature range		-29 to 250°C	100 to 250°C	100 to 250°C	-29 to 250°C	-29 to 250°C	-29 to 250°C
Accuracy (Note 2)	Mass flow	Refer to table 7					
	Temperature	----	±0.5% of rate	±1% of rate	±1°C (Less than 100°C) ±1% of rate (100°C or more)	±0.5°C (Less than 100°C) ±0.5% of rate (100°C or more)	----
Temperature response (50% response)		60 sec (Churning Underwater)					----
Mass Flow calculation Method		----	Density Calculation (Note 3)	Density Calculation (Constant pressure is assumed) (Note 4)	Temp.- Pressure Correction (Constant pressure is assumed) (Note 5)	Density change Calculation (Note 6)	----
Output	Analog Output	Select from Flow rate or temperature (Note 7)					Only for Flow rate
	Pulse output	Only for Flow rate					Only for Flow rate
	Alarm Output	Standard Alarm + Error of thermometer etc.					Only for Standard
	Status output	Only for Flow Switch					Flow Switch
Display	Upper	Select from Flow rate (% , Engineering unit) or temperature (%) (Note 8)					Only for Flow rate
	Lower	Select from Total Rate or temperature (°C, °F) (Note 9)					Only for Flow rate
Remote Type		Flow Converter : Select DYA-□□□/MV Signal Cable : Select DYC-□□□/MV (Note10)					----

(Note 1) When /MV is selected /HT is not available.

(Note 2) For detailed accuracy, see "SIZING" Measurement temperature is changed by the heat-insulation method of piping and piping method. Refer to "REMARKS ON INSTALLATION" about heat-insulation. In case of the Mass Flow measurement of saturated steam and superheated steam, it is necessary to make a heat-insulation.

(Note 3) Mass Flow rate is calculated from density values by temperature measurement using saturated steam table.

(Note 4) Mass Flow rate is calculated from density values to temperature measured by using steam table. In order to measure superheated steam, it is necessary to make constant pressure value. A pressure value which is indicated by order sheet is used.

(Note 5) In order to measure gas, Pressure-Temperature correction is carried out. It is necessary to make constant pressure value. In addition to pressure values at operational condition or temperature and pressure value at standard condition which is indicated when ordered, which is indicated by order sheet.

(Note 6) In order to measure mass flow rate of liquid applications, the density at normal condition is used, and if fluid temperature deviates from normal temperature, density value is calculated by 2 dimensional equation. In this case, temperature coefficient should be prepared by user's side.

(Note 7) Default setting is Flow rate. It is necessary to change the parameter of output in case of setting temperature output.

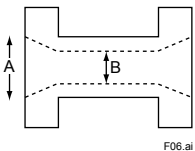
(Note 8) In case of indicating the temperature %, the display indicate not only "%" but also "t". ("t" is the means of temperature)

(Note 9) Default setting is "temperature" but "Total " is setup when ordering the Total Rate.

(Note 10) In case of Multi variable (/MV), it is necessary to setup the parameter of Cable Length.

OPTION SPEC FOR REDUCED BORE TYPE (/R1) (Note 1)

This option is the same as standard specification except the following items.

		Reduced Bore Type (Option: /R1) (Note1)		
(Note 2) 	Model Code	Flange piping size (A)	R1 Detector size (inner dia.) (B)	[Pressure Loss] R1: about 15% increase to standard type Refer to P.18
	DY025	25mm	15 (14.6) (mm) (Note 3)	
	DY040	40mm	25 (25.7) (mm)	
	DY050	50mm	40 (39.7) (mm)	
	DY080	80mm	50 (51.1) (mm)	
	DY100	100mm	80 (71) (mm)	
	DY150	150mm	100 (93.8) (mm)	
	DY200	200mm	150 (138.8) (mm)	
Measurable minimum flow velocity	Liquid, Gas, Steam		Refer to Table 5	
Range of measurable flow velocity	Liquid, Gas, Steam		Refer to Table 6	

(Note 1) For accuracy, refer to "Detailed Accuracy"(P.13, P.14).

(Note 2) Flange type only: refer to page 7 table 2

(Note 3) High process temperature version /HT and Multi-variable type /MV for DY025/R1 not available.

OPTION SPEC FOR DUAL VORTEX CALIBRATION (/DC1, /DC2)

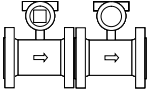
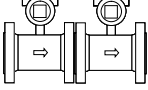
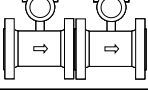
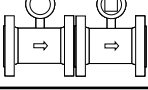
Orientation	Upstream	Downstream	Upstream	Downstream
	DY015 - 050		DY080 - 200	
	DY()()-.../DC1	DY()()-.../DC2/CRC	DY()()-.../DC1	DY()()-.../DC2/CRC
	not possible	not possible	DY()()-.../DC1	DY()()-.../DC2
	not possible	not possible	DY()()-.../DC1/CRC	DY()()-.../DC2/CRC
	not possible	not possible	not possible	not possible

Table 4 Test Pressure Value

Flange Rating	Pressure
ANSI Class 150	2.9 MPa (29 bar)
ANSI Class 300	7.5 MPa (75 bar)
ANSI Class 600	14.9 MPa (149 bar)
ANSI Class 900	22.4 MPa (223 bar)
DIN PN 10	1.5 MPa (15 bar)
DIN PN 16	2.4 MPa (24 bar)
DIN PN 25	3.8 MPa (37.5 bar)
DIN PN 40	5.9 MPa (60 bar)
DIN PN 64	9.6 MPa (96 bar)
DIN PN 100	15 MPa (150 bar)
DIN PN 160	24 MPa (240bar)

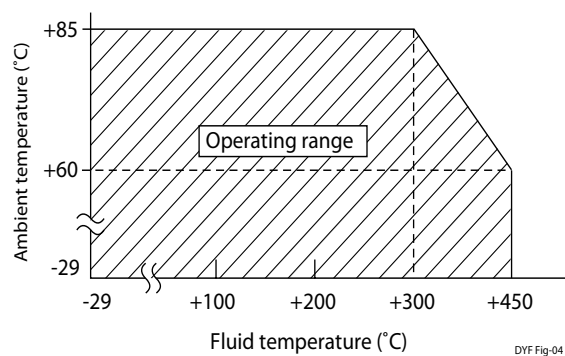


Figure 4 Fluid temperature range of high process temperature version

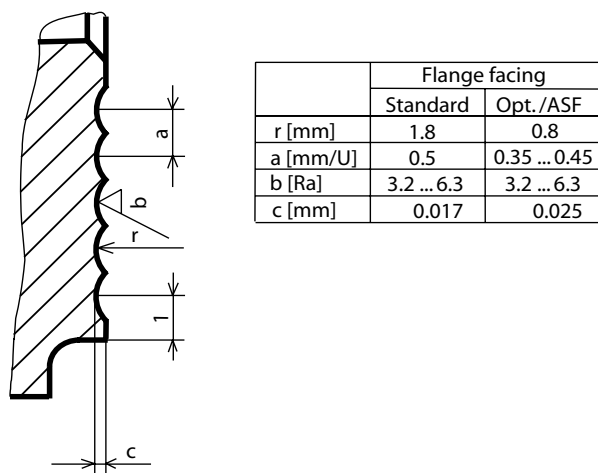


Figure 5 Finish of ANSI flange faces

SIZING

The following items are the basic specifications.

In case of the definite sizing, it is necessary to check by the sizing software.

Measurable minimum flow velocity

Table 5 Relationship between Minimum Velocity and Density (In case of “Gas, Steam”, Use the Larger of the Two Values)

Model Code		Liquid		Gas, Steam (Note1)	
Standard Type, Multi-Variable Type/(MV)	Reduced Bore Type (/R1) (Note2)	Standard Type, Cryogenic Version (/LT)(Note2), Multi-Variable Type (/MV) Unit: m/s	High Process Temperature Version(/HT), High Process Temperature Version Multi-Variable Type (/HT/MV) Unit: m/s	Standard Type, Cryogenic Version (/LT)(Note2), Multi-Variable Type (/MV) Unit: m/s	High Process Temperature Version(/HT), High Process Temperature Version Multi-Variable Type (/HT/MV) Unit: m/s
DY015	DY025/R1	$\sqrt{250/\rho}$	—	$\sqrt{80/\rho}$ or 3	—
DY025	DY040/R1	$\sqrt{122.5/\rho}$	$\sqrt{490/\rho}$	$\sqrt{45/\rho}$ or 2	$\sqrt{125/\rho}$ or 2
DY040	DY050/R1	$\sqrt{90/\rho}$	$\sqrt{302.5/\rho}$	$\sqrt{31.3/\rho}$ or 2	$\sqrt{90.3/\rho}$ or 2
DY050	DY080/R1	$\sqrt{90/\rho}$	$\sqrt{160/\rho}$	$\sqrt{31.3/\rho}$ or 2	$\sqrt{61.3/\rho}$ or 2
DY080	DY100/R1	$\sqrt{90/\rho}$	$\sqrt{160/\rho}$	$\sqrt{31.3/\rho}$ or 2	$\sqrt{61.3/\rho}$ or 2
DY100	DY150/R1	$\sqrt{90/\rho}$	$\sqrt{160/\rho}$	$\sqrt{31.3/\rho}$ or 2	$\sqrt{61.3/\rho}$ or 2
DY150	DY200/R1	$\sqrt{90/\rho}$	$\sqrt{160/\rho}$	$\sqrt{31.3/\rho}$ or 3	$\sqrt{61.3/\rho}$ or 3
DY200	—	$\sqrt{122.5/\rho}$	$\sqrt{202.5/\rho}$	$\sqrt{45/\rho}$ or 3	$\sqrt{80/\rho}$ or 3

ρ : Density at operating conditions (kg/m³), Liquid density range is 400 to 2000 kg/cm³

(Note1) The case of gas, it is whichever is greater than a fixed value of each model and calculated from density.

Guaranteed accuracy at minimum flow velocity

Table 6 Range of Measurable flow velocity

Fluid	Model Code		Minimum flow velocity	Maximum flow velocity
Liquid	DY015 to DY200	DY025 /R1 to DY200 /R1	“flow velocity obtained from Table 5” or “flow velocity at Reynolds number of 5000”, whichever is greater. For liquid Reynolds number of 5000: Refer to P.15 “Calculation formula.”	10m/s
Gas, Steam	DY015 to DY200	DY025 /R1 to DY200 /R1	“flow velocity obtained from Table 5” or “flow velocity at Reynolds number of 5000”, whichever is greater. For Gas and steam Reynolds number of 5000: Refer to P.15 “Calculation formula.”	80m/s

When the flow velocity is lower than minimum, both the analog output and the pulse output is displayed as “0”

Table 7 Range of Guaranteed Accuracy Flow Velocity

Fluid	Model Code		Minimum flow velocity	Maximum flow velocity
Liquid	DY015 to DY100	DY025 /R1 to DY150 /R1	“flow velocity obtained from Table 5” or “flow velocity at Reynolds number of 20000”, whichever is greater. For liquid Reynolds number of 20000: The value is four times velocity value in P.15 “Calculation formula.”	10m/s
	DY150 to DY200	DY200 /R1	“flow velocity obtained from Table 5” or “flow velocity at Reynolds number of 40000”, whichever is greater. For liquid Reynolds number of 40000: The value is eight times velocity value in P.15 “Calculation formula.”	
Gas, Steam	DY015 to DY100	DY025 /R1 to DY150 /R1	“flow velocity obtained from Table 5” or “flow velocity at Reynolds number of 20000”, whichever is greater. For gas and steam Reynolds number of 20000: Refer to P.15 “Calculation formula.”	80m/s
	DY150 to DY200	DY200 /R1	“flow velocity obtained from Table 5” or “flow velocity at Reynolds number of 40000”, whichever is greater. For gas and steam Reynolds number of 40000: Refer to P.15 “Calculation formula.”	

Detailed Accuracy (for Table 7 Range of fixed Accuracy Flow Velocity)

Volumetric flow rate at operation condition

	Model Code	Standard Type	Multi-Variable Type (MV)	Reduced Bore Type (R1)
Liquid	DY015	±1.0% (20000≤Re<2000*D) ±0.75% (2000*D≤Re)		
	DY025	±1.0% (20000≤Re<1500*D) ±0.75% (1500*D≤Re)	±1.0% (20000≤Re<1500*D) ±0.75% (1500*D≤Re)	
	DY040	±1.0% (20000≤Re<1000*D) ±0.75% (1000*D≤Re)	±1.0% (20000≤Re<1000*D) ±0.75% (1000*D≤Re)	±1.0%
	DY050			
	DY080			
	DY100			
	DY150	±1.0% (40000≤Re<1000*D) ±0.75% (1000*D≤Re)	±1.0% (40000≤Re<1000*D) ±0.75% (1000*D≤Re)	±1.0% (40000≤Re)
DY200				
Gas, Steam	DY015	±1.0% (Velocity 35m/s or less) ±1.5% (Velocity 35m/s to 80m/s)	±1.0% (Velocity 35m/s or less) ±1.5% (Velocity 35m/s to 80m/s)	±1.0% (Velocity 35m/s or less) ±1.5% (Velocity 35m/s to 80m/s)
	DY025			
	DY040			
	DY050			
	DY080			
	DY100			
	DY150			
DY200				

D: Inner diameter of digitalYEWFL0 (mm)

Re: Reynolds number

Note: This table shows the accuracy of pulse output. In case of analog output, add up ± 0.1% of full scale to the values mentioned above.

Guarantee conditions of liquid volumetric flow rate: the accuracy of a product before shipment in our water actual test facility.

Totalized value of 2000 pulse or greater, straight pipe length: upper 10D or greater, lower 5D or greater, Fluid temp. 20 ± 10°C

Gas, Steam: The accuracy which is add up from liquid measurement accuracy.

The accuracy is confirmed by actual measured value of typical nominal size.

Mass flow or Volumetric flow rate at Normal/Standard condition:

for Multi-Variable Type and combination of Multi-Variable Type and Reduced Bore Type

	Model Code	MV	MV/R1
Liquid	DY025	±2.0% (20000≤Re<1500*D) ±1.5% (1500*D≤Re)	
	DY040	±2.0%(20000≤Re<1000*D) ±1.5% (1000*D≤Re)	±2.0% (20000≤Re)
	DY050		
	DY080		
	DY100		
	DY150	±2.0% (40000≤Re<1000*D) ±1.5% (1000*D≤Re)	±2.0% (40000≤Re)
DY200			
Gas, Steam	DY025	±2.0% (Velocity 35m/s or less) ±2.5% (Velocity 35m/s to 80m/s)	±2.0% (Velocity 35m/s or less) ±2.5% (Velocity 35m/s to 80m/s)
	DY040		
	DY050		
	DY080		
	DY100		
	DY150		
	DY200		

D : Inner diameter of digitalYEWFL0 detector (mm)

Re: Reynolds number

Note: This table shows the accuracy of pulse output. In case of analog output, add up ± 0.1% of full scale to the values mentioned above.

Calculation formula

How to calculate volume flow rate at operating conditions.

$$\bullet Q_f = 3600 \times v \times S \quad \text{or} \quad Q_f = \frac{v \times D^2}{354}$$

How to calculate the velocity of a Reynolds number.

- $v = 5 \times v / D$ (Reynolds number of 5000)
- $v = 20 \times v / D$ (Reynolds number of 20000)
- $v = 40 \times v / D$ (Reynolds number of 40000)

however

$$\bullet Re = \frac{354 \times 10^{-3} \times Q_f}{v \times D} \quad \dots\dots\dots (1)$$

$$\bullet v = \frac{\mu}{\rho f} \times 10^{-3} \quad \dots\dots\dots (2)$$

- Qf : Volume flow rate at operating conditions (m³/h)
- D : Inner diameter of YEWFLO (mm)
- S : Cross section of YEWFLO (m²)
- v : Flow velocity (m/s)
- Re : Reynolds number (none unit)
- Pf : Density at operating conditions (kg/m³)
- μ : Viscosity at operating conditions (mPa·s{cP})
- v : Kinematic viscosity at operating conditions (10⁻⁶m²/s{cSt})

Typical fluid example

Table 8 Range of Measurable Water Flow Rate
(At standard condition of 15 °C, ρ = 1000 kg/m³)

Model Code		Measurable Flow Rate in m ³ /h	Range of Fixed Accuracy Flow Rate in m ³ /h
	Inner diameter in mm		
DY015	14.6	0.30 to 6	0.94 to 6
DY025	25.7	0.65 to 18	1.7 to 18
DY040	39.7	1.3 to 44	2.6 to 44
DY050	51.1	2.2 to 73	3.3 to 73
DY080	71.0	4.3 to 142	4.6 to 142
DY100	93.8	7.5 to 248	7.5 to 248
DY150	138.8	17 to 544	18 to 544
DY200	185.8	34 to 973	34 to 973

Table 9 Range of Measurable Air Flow Rate at Selected Process Pressures

Model Code		Flow Rate Limits	Minimum and Maximum Measurable Flow Rate in Nm ³ /h									
			0 MPa	0.1 MPa	0.2 MPa	0.4 MPa	0.6 MPa	0.8 MPa	1 MPa	1.5 MPa	2 MPa	2.5 MPa
DY015	DY025/R1	min.	4.8(11.1)	6.7(11.1)	8.2(11.1)	10.5(11.1)	12.5	16.1	19.7	28.6	37.5	46.4
		max.	48.2	95.8	143	239	334	429	524	762	1000	1238
DY025	DY040/R1	min.	11.0(19.5)	15.5(19.5)	19.0(19.5)	24.5	29.0	33.3	40.6	59.0	77.5	95.9
		max.	149	297	444	739	1034	1329	1624	2361	3098	3836
DY040	DY050/R1	min.	21.8(30.0)	30.8	37.8	48.7	61.6	79.2	97	149	184	229
		max.	356	708	1060	1764	2468	3171	3875	5634	7394	9153
DY050	DY080/R1	min.	36.2(38.7)	51	62.4	80.5	102	131	161	233	306	379
		max.	591	1174	1757	2922	4088	5254	6420	9335	12249	15164
DY080	DY100/R1	min.	70.1	98.4	120	155	197	254	310	451	591	732
		max.	1140	2266	3391	5642	7892	10143	12394	18021	23648	29274
DY100	DY150/R1	min.	122	172	211	272	334	442	540	786	1031	1277
		max.	1990	3954	5919	9847	13775	17703	21632	31453	41274	51095
DY150	DY200/R1	min.	268	377	485	808	1131	1453	1776	2583	3389	4196
		max.	4358	8659	12960	21559	30163	38765	47365	68867	90373	111875
DY200	—	min.	575	809	990	1445	2202	2599	3175	4617	6059	7501
		max.	7792	15482	23172	38549	53933	69313	84693	123138	161591	200046

- (1) Listed flow rate is at standard conditions STP (0°C, 1atm).
- (2) Listed gauge pressure is at process temperature of 0°C.
- (3) Maximum flow rate is the lower of 80m/s.
- (4) Minimum flow rate: (value) is the lower limit of the accuracy range.

Table 10 Range of Measurable Saturated Steam Flow Rate at Selected Process Pressures

Model Code		Flow Rate Limits	Minimum and Maximum Measurable Flow Rate in kg/h									
			0.1 MPa	0.2 MPa	0.4 MPa	0.6 MPa	0.8 MPa	1 MPa	1.5 MPa	2 MPa	2.5 MPa	3 MPa
DY015	DY025/R1	min.	5.8(10.7)	7.0(11.1)	8.8(11.6)	10.4(12.1)	11.6(12.3)	12.8	15.3	19.1	23.6	28.1
		max.	55.8	80	129	177	225	272	390	508	628	748
DY025	DY040/R1	min.	13.4(18.9)	16.2(20.0)	20.5	24.1	27.1	30	36	41	49	58
		max.	169.7	247.7	400	548	696	843	1209	1575	1945	2318
DY040	DY050/R1	min.	26.5(29.2)	32	40.6	47.7	53.8	59	72	93	116	138
		max.	405	591	954	1310	1662	2012	2884	3759	4640	5532
DY050	DY080/R1	min.	44.0	53	67.3	79	89	98	119	156	192	229
		max.	671	979	1580	2170	2753	3333	4778	6228	7688	9166
DY080	DY100/R1	min.	84.9	103	130	152	171	189	231	300	371	442
		max.	1295	1891	3050	4188	5314	6435	9224	12024	14842	17694
DY100	DY150/R1	min.	148	179	227	267	300	330	402	524	647	772
		max.	2261	3300	5326	7310	9276	11232	16102	20986	25907	30883
DY150	DY200/R1	min.	324	392	498	600	761	922	1322	1723	2127	2536
		max.	4950	7226	11661	16010	20315	24595	35258	45953	56729	67624
DY200	—	min.	697	841	1068	1252	1410	1649	2364	3081	3803	4534
		max.	8851	12918	20850	28627	36325	43976	63043	82165	101433	120913

- (1) Maximum flow rate is the lower of 80m/s.
- (2) Minimum values are determined from Table 7. The values in parenthesis show the minimum linear flow rates (Re = 20,000 or 40,000) when they are higher than the minimum measurable flow rate.

Reference

Table 11 Inner Diameter and Nominal value

Model Code		Inner Diameter mm	Nominal K-Factor Pulse/L	Nominal Pulse Rate	
				Hz / m/s	Hz / m ³ /h
DY015	DY025 /R1	14.6	376	62.7	104
DY025	DY040 /R1	25.7	68.6	35.5	19.1
DY040	DY050 /R1	39.7	18.7	23.1	5.19
DY050	DY080 /R1	51.1	8.95	18.3	2.49
DY080	DY100 /R1	71.0	3.33	13.2	0.925
DY100	DY150 /R1	93.8	1.43	9.88	0.397
DY150	DY200 /R1	138.8	0.441	6.67	0.123
DY200	—	185.6	0.185	5.00	0.0514

Pressure Loss

Calculation of pressure loss for general type

obtained from the following equations.

$$\Delta P = 108 \times 10^{-5} \times \rho_f \times v^2 \dots\dots\dots (1)$$

or

$$\Delta P = 135 \times \rho_f \times \frac{Q_f^2}{D^4} \dots\dots\dots (2)$$

where,

- ΔP : Pressure loss (kPa)
- ρ_f : Density at operating condition (kg/m³)
- v : Flow velocity (m/s)
- Q_f : Actual flow rate (m³/h)
- D : Internal Diameter of detector (mm)

(Example)

DY050, hot water: 80 °C, flowrate: 30 m³/h

- Since the density of water at 80 °C is 972 kg/m³, substitute this value in equation (2):

$$\Delta P = 135 \times 972 \times 30^2 / 51.1^4 = 17.3 \text{ kPa}$$

- Obtain the pressure loss using equation (1). The flow velocity when the flow rate is 30 m³/h is given by:

$$v = 354 \times Q_f / D^2 = \frac{354 \times 30}{51.1^2} = 4.07 \text{ m/s}$$

Therefore, substitute this value in equation (1):

$$\Delta P = 108 \times 10^{-5} \times 972 \times 4.07^2 = 17.3 \text{ kPa}$$

Calculation of pressure loss for reduced bore type (Option code: /R1)

obtained from the following equations.

$$\Delta P = 124 \times 10^{-5} \times \rho_f \times v^2 \dots\dots\dots (3)$$

or

$$\Delta P = 155 \times \rho_f \times Q_f^2 / D^4 \dots\dots\dots (4)$$

(Example)

DY040-/R1, hot water: 50 °C, flowrate: 10 m³/h

- Since the density of water at 50 °C is 992 kg/cm³, substitute this value in equation (4):

$$\Delta P = 155 \times 992 \times 10^2 / 25.7^4 = 35.3 \text{ kPa}$$

- Obtain by using equation (3). The flow velocity when the flow rate is 10 m³/h is given by:

$$v = 354 \times Q_f / D^2 = \frac{354 \times 10}{25.7^2} = 5.4 \text{ m/s}$$

Therefore, substitute this value in equation (3):

$$\Delta P = 124 \times 10^{-5} \times 992 \times 5.4^2 = 35.3 \text{ kPa}$$

Cavitation

(Minimum Back Pressure, Liquid service only):

Cavitation occurs when the flow line pressure is low and flow velocity is high during fluid measurement, preventing correct measurement of flow rate. The optimum line pressure can be obtained from the following equation.

$$P = 2.7 \times \Delta P + 1.3 \times P_o \dots\dots\dots (5)$$

Where,

- P : Line pressure, 2 to 7 times as large as internal diameter on downstream of flowmeter body surface. (kPa absolute).
- ΔP : Pressure loss (kPa). Refer to the item above.
- P_o : Saturation liquid vapor pressure at operating temperature (kPa absolute).

(Example) Confirmation of presence of cavitation

Suppose that the line pressure is 120 kPa abs and the flow rate scale is 0 to 30 m³/h. It is only necessary to confirm the pressure at the maximum flow rate; therefore, the saturated steam pressure of water at 80 °C is as follows from the table of saturated steam pressures:

$$P_o = 47.4 \text{ kPa abs}$$

Therefore, substitute this value in equation (5):

$$P = 2.7 \times 17.3 + 1.3 \times 47.4 = 108.3 \text{ kPa abs}$$

Since the operating pressure of 120 kPa abs is higher than 108.3 kPa abs, no cavitation occurs.

REMARKS ON INSTALLATION

Piping support

Typical vibration immunity level is 1G for normal piping condition. Piping support should be fixed in case of over 1G vibration level.

Installation direction

If a pipe is always filled with liquids, the pipe can be installed vertically or at inclined angle

Adjacent pipes

The process pipeline inner diameter should be larger than the digitalYEWFLOW inner diameter.

Use the following adjacent pipe.

Model Code DY015 up to DY050, DY025-/R1 up to DY080-/R1: Sch 40 or less.

Model Code DY080 up to DY200, DY100-/R1 up to DY200-/R1: Sch 80 or less.

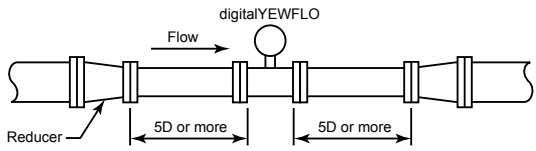
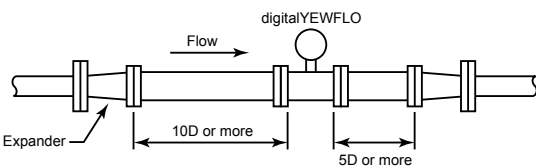
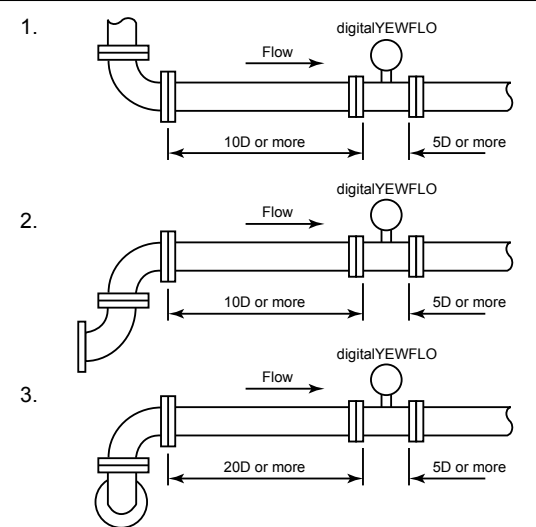
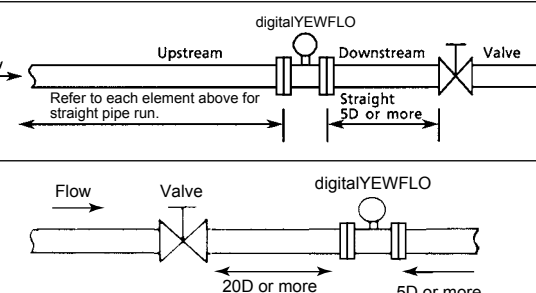
Straight pipe length

*D: piping diameter

*K-factor may be influenced about 0.5 % in case that straight pipe length of upstream is less than values below.

● Straight pipe length and recommendations (1)

D: Nominal diameter (mm)

Description	Figure
<p>Reducer pipe: Ensure the upstream straight pipe length to be 5D or more, and the downstream straight pipe length to be 5D or more for per reducer pipe.</p>	
<p>Expander pipe: Ensure the upstream straight pipe length to be 10D or more, and the downstream straight pipe length to be 5D or more for per expander pipe.</p>	
<p>Bent pipe and straight pipe length:</p> <ol style="list-style-type: none"> 1. Single bent pipe 2. Double bent pipe; coplanar 3. Double bent pipe; non coplanar 	
<p>Valve position and straight pipe length:</p> <p>n Install the valve on the downstream side of the flowmeter. The upstream straight pipe length dependent on the element located on the upstream such as reducer/expander, bent and etc., refer to description as above. Keep 5D or more for downstream straight pipe length.</p> <p>n In case the valve has to be installed on the upstream of the flowmeter, ensure the upstream straight pipe length to be 20D or more, and the downstream straight pipe length be 5D or more.</p>	

● **Straight pipe length and recommendations (2)**

D: Nominal diameter (mm)

Description	Figure
<p>Fluid vibration:</p> <p>For a gas line which uses a position-type or roots-type blower compressor or a high-pressure liquid line (about 1MPa or more) which uses piston-type or plunger-type pump, fluid vibrations may be produced.</p> <p>In these case, install valve on the upstream side of digitalYEWFLOW.</p> <p>For inevitable fluid vibration, put a vibration damping device such as throttling plate or expansion section in the upstream side of digitalYEWFLOW.</p>	
<p>Piston-type or plunger pump:</p> <p>Install the accumulator on the upstream side of digitalYEWFLOW to reduce fluid vibrations.</p>	
<p>Valve positon (T-type piping exist):</p> <p>When pulsation causes by a T-type piping exist, install the valve on the upstream of the flowmeter.</p> <p>Example: As shown in the figure, when the valve V1 is turned off, the fluid flow throught B as to meter A the flow is zero. But due to the pulsating pressure is detected, the meter is zero point become fluctuating. To avoid this, change the valve V1 location to V1'.</p> <p>Note: In case of the Reduced Bore Type, moisture may be remained upstream of the flowmeter. Drain it appropriately.</p>	
<p>Pressure and Temperature Taps:</p> <p>Pressure tap outlet: install this tap between 2D and 7D on the downstream side of a flowmeter.</p> <p>Temperature tap outlet: install this on the downstream side 1D to 2D away from a pressure tap.</p>	
<p>Mounting Gasket:</p> <p>Avoid mounting gaskets which protrude into the pipe line. This may cause inaccurate readings.</p> <p>Use the gaskets with bolt holes, even if digitalYEWFLOW is the wafer type.</p> <p>When using a spiral gasket (without bolt holes), confirm the size with the gasket -manufacturer, as standard items may not be used for certain flange ratings.</p>	

● Straight pipe length and recommendations (3)

D: Nominal diameter (mm)

Description	Figure
<p>Heat-Insulation:</p> <p>When an integral-type flowmeter or a remote type detector is installed and the pipe carrying high-temperature fluids is heat-insulated, do not wrap adiabatic materials around the installation the bracket (DY015 to DY100) or the nozzle (DY150 to DY400) of the converter.</p> <p>If the application requires the use of /HT instruments, please see User's manual for insulation recommendations.</p>	
<p>Flushing of the pipe line:</p> <p>Flush and clean scale, incrustation and sludge on the inside of pipe for newly installed pipe line and repaired pipe line before the operation. For flushing, the flow should flow through bypass-piping to avoid damaging the flowmeter. If there is no bypass-piping, install short pipe instead of the flowmeter.</p>	

● The wiring example for the analog and pulse and status, alarm output.

Connection	Description
<p>Analog Output</p> <p>In this case, Communication is possible (up to a distance of 2km when a CEV cable is used.)</p>	<p>digitalYEWFLOW Electrical Terminal</p>
<p>Pulse Output</p> <p>In this case, No communication is possible.</p>	<p>digitalYEWFLOW Electrical Terminal</p> <p>Shielded Cable</p>
<p>Status Output Alarm Output</p> <p>In this case, No communication is possible.</p>	<p>digitalYEWFLOW Electrical Terminal</p> <p>Shielded Cable</p>

*1: To avoid the influence of external noise, use an electric counter which fits to the pulse frequency.

*2: Resistor is not necessary in case of an electric counter which can receive contact pulse signal directly.

● The wiring example for the the simultaneous analog and pulse output, the calculation formula of the range of load resistance R for the pulse output.

Connection	Description
<p>Simultaneous Analog -Pulse Output ^{*3}</p> <p>Example 1 In this case, Communication is possible (up to a distance of 2km when a CEV cable is used).</p> <p>Example 2 In this case, Communication is possible (up to a distance of 200m when a CEV cable is used) and R = 1kΩ).</p> <p>Example 3 In this case, No commcation is possible (when shielded cable is not used).</p>	<p>When analog and pulse output are used, the length of communication line is subjected to wiring conditions. Refer to example 1 to 3. If the communication carries out from amplifier, no need to consider wiring conditions.</p> <p>digitalYEWFL0 Electrical Terminal</p> <p>Electric counter *1 (or communication medium)</p> <p>Recorder or other instrument</p> <p>Electric counter *1 (or communication medium)</p> <p>Recorder or other instrument</p> <p>Electric counter *1 (or communication medium)</p>
<p>The range of load resistance R for the pulse output.</p>	<p>The load resistance should be selected by calculation as shown below.</p> $\frac{E (V) ^{*5}}{120} \leq R (k\Omega) \leq \frac{0.1}{C (\mu F) \times f (kHz)}$ <p>Example of CEV cable capacitance $\approx 0.1\mu F/km$</p> $P (mW) = \frac{E^2 (V)}{R (k\Omega)}$ <p>Where E = Supply voltage (V) f = Frequency of pulse output (kHz) R = Value of load resistance (kΩ) C = Cable capacitance (μF) P = Power ratio of the load resistance (mW)</p>

*1: To avoid the influence of external noise, use an electric counter which fits to the pulse frequency.

*2: Resistor is not necessary in case of an electric counter which can receive contact pulse signal directly.

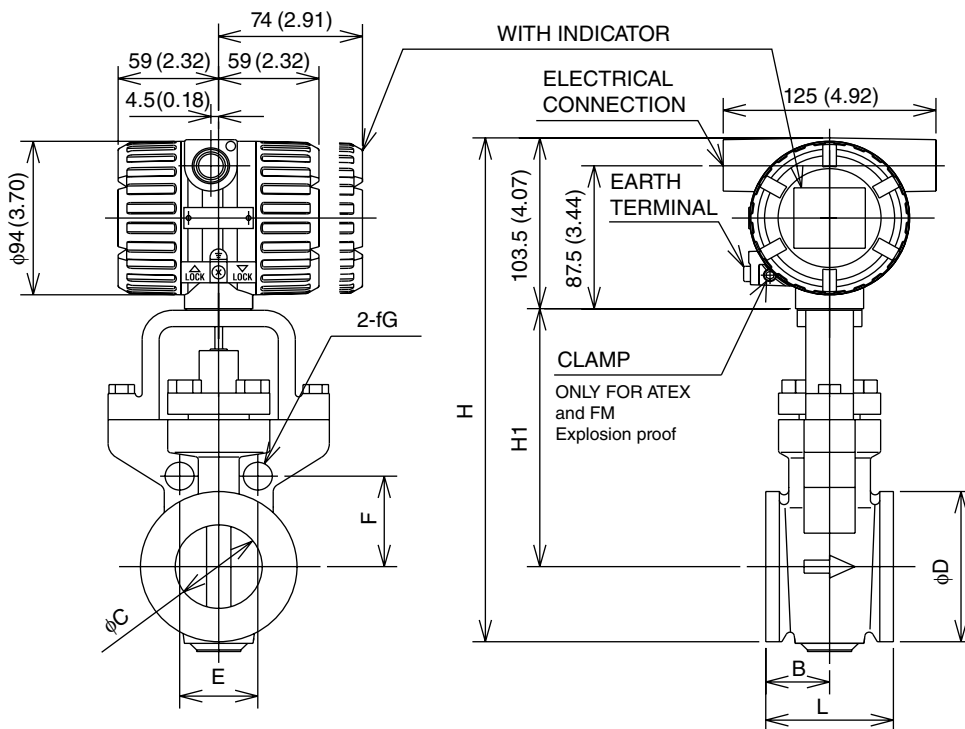
*3: When using analog and pulse output simultaneously, the HART communication may be influenced by noise comparing analog output only.

*5: $\frac{E (V)}{80}$ for /KS2 and /SS2

EXTERNAL DIMENSIONS

Wafer type (DY015 up to DY100)

Unit: mm
(approx. in)



TYPE	INTEGRAL/REMOTE													
CODE	DY015 (15mm, 1/2 in)							DY025 (25mm, 1 in)						
PROCESS CONNECTION	AA1	AA2	AA4	AD4	N/A	N/A	N/A	AA1	AA2	AA4	AD4	N/A	N/A	N/A
L	70 (2.76)							70 (2.76)						
B	35 (1.38)							35 (1.38)						
C	14.6 (0.57)							25.7 (1.01)						
D	35.1 (1.38)							50.8 (2.00)						
H	248 (9.76)							258 (10.16)						
H1	127 (5.00)							129 (5.08)						
E	42.7 (1.68)	47.1 (1.85)	47.1 (1.85)	46 (1.81)				56 (2.21)	62.9 (2.48)	62.9 (2.48)	60.1 (2.37)			
F	21.4 (0.84)	23.5 (0.93)	23.5 (0.93)	23 (0.91)				26 (1.0)	31.4 (1.24)	31.4 (1.24)	30.1 (1.19)			
G	14 (0.55)	14 (0.55)	14 (0.55)	13 (0.51)				14 (0.55)	17 (0.67)	17 (0.67)	13 (0.51)			
WEIGHT kg	2.8 (6.17lb)							3.7 (8.16lb)						

TYPE	INTEGRAL/REMOTE													
CODE	DY040 (40mm, 1 1/2 in)							DY050 (50mm, 2 in)						
PROCESS CONNECTION	AA1	AA2	AA4	AD4	N/A	N/A	N/A	AA1	AA2	AA4	AD4	N/A	N/A	N/A
L	70 (2.76)							75 (2.95)						
B	35 (1.38)							37.5 (1.48)						
C	39.7 (1.56)							51.1 (2.01)						
D	73 (2.87)							92 (3.62)						
H	276 (10.87)							307.5 (12.11)						
H1	136 (5.35)							158 (6.22)						
E	69.7 (2.74)	80.8 (3.18)	80.8 (3.18)	77.8 (3.06)				(Note 3)	48.6 (1.91)	48.6 (1.91)	(Note 3)			
F	34.8 (1.37)	40.4 (1.59)	40.4 (1.59)	36.9 (1.45)				(Note 3)	58.7 (2.31)	58.7 (2.31)	(Note 3)			
G	14 (0.55)	20 (0.79)	20 (0.79)	17 (0.67)				(Note 3)	17 (0.67)	17 (0.67)	(Note 3)			
WEIGHT kg	4.3 (9.48lb)							6.0 (13.23lb)						

TYPE	INTEGRAL/REMOTE													
CODE	DY080 (80mm, 3 in)							DY100 (100mm, 4 in)						
PROCESS CONNECTION	AA1	AA2	AA4	AD4	N/A	N/A	N/A	AA1	AA2	AA4	AD2	AD4	N/A	N/A
L	100 (3.94)							120 (4.72)						
B	40 (1.57)							50 (1.97)						
C	71 (2.80)							93.8 (3.69)						
D	127 (5.00)							157.2 (6.19)						
H	342 (13.47)							372 (14.65)						
H1	175 (6.89)							190 (7.48)						
E	(Note 3)	64.4 (2.54)	64.4 (2.54)	61.2 (2.41)				72.9 (2.87)	76.6 (3.02)	82.6 (3.25)	68.9 (2.71)	72.7 (2.86)		
F	(Note 3)	77.7 (3.06)	77.7 (3.06)	73.9 (2.91)				88 (3.46)	92.5 (3.64)	99.7 (3.93)	83.1 (3.27)	87.8 (3.46)		
G	(Note 3)	20 (0.79)	20 (0.79)	17 (0.67)				17 (0.67)	20 (0.79)	23 (0.91)	17 (0.67)	21 (0.83)		
WEIGHT kg	9.4 (20.73lb)							12.8 (28.22lb)						

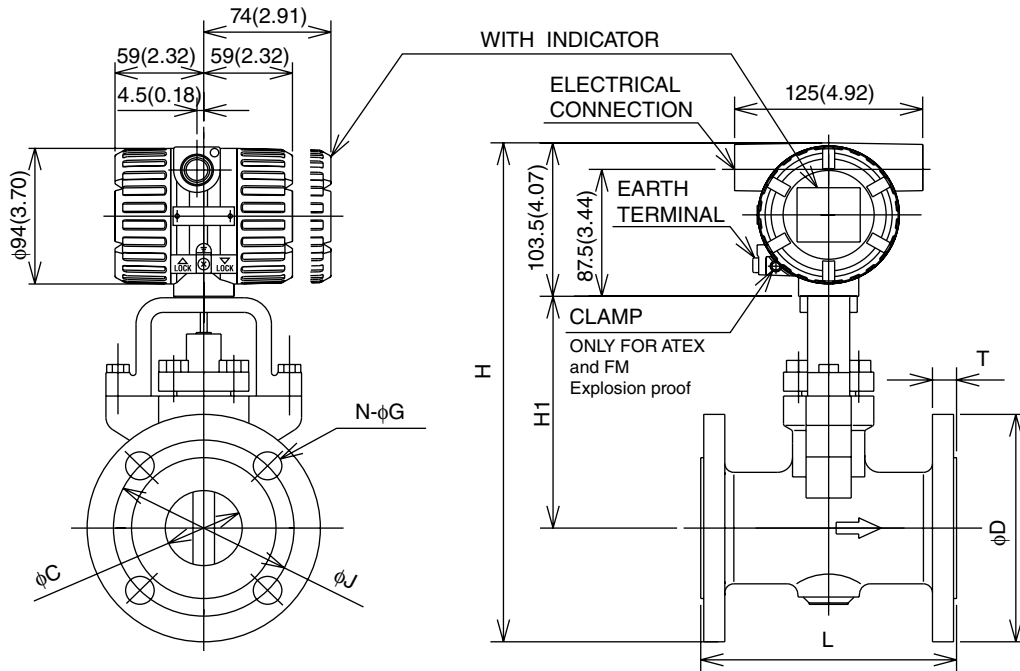
(Note 1) Integral weight is the same as Remote.

(Note 2) In case of with Indicator, add 0.2kg.

(Note 3) The hole is not provided.

(Note 4) The flow direction is opposite (right to left when facing onto indicator) in case of code /CRC.

Unit: mm
(approx. in)



TYPE	INTEGRAL/REMOTE																			
	DY015 (15mm, 1/2 in)									DY025 (25mm, 1 in)										
PROCESS CONNECTION	BA1	BA2	BA4	LA5	BD4	BD6	BD7	CA4	RA5	N/A	BA1	BA2	BA4	LA5	BD4	BD6	BD7	N/A	CA4	RA5
L	130	160	130	140	160	140	160	170	190	190	150	150	150	150	150	150	150	150	170	190
C	14.6 (0.58)																			
D	88.9	95.3	120.7	95	105	105	120.7	105	120.7	105	108	124	124	149.4	115	140	140	140	124	149.4
H	275	278	278	291	278	283	283	278	291	283	286.5	294.5	294.5	307	290	302.5	303	294.5	294.5	307
H1	127 (5.00)																			
T	11.2	14.2	21	28.8	16	20	19.9	28.8	14.2	17.5	24	34.9	18	24	24	24	24	24	34.9	18
J	60.5	66.5	66.5	82.6	65	75	66.5	82.6	79.2	89	89	101.6	85	100	100	89	101.6	89	101.6	89
N	4 (0.16)																			
G	15.7	15.7	15.7	22.4	14	14	15.7	22.4	15.7	19	19	25.4	14	18	18	18	18	19	25.4	18
WEIGHT	kg	4.1	4.3	4.6	6.7	4.2	5.4	5.4	4.5	6.8	6.6	7.2	7.7	11.1	6.9	9.6	9.6	7.9	11.4	11.4
	lb	9.04	9.48	10.14	14.77	9.26	11.91	11.91	9.92	14.99	14.55	15.88	16.98	24.48	15.21	21.16	21.16	17.42	25.14	25.14

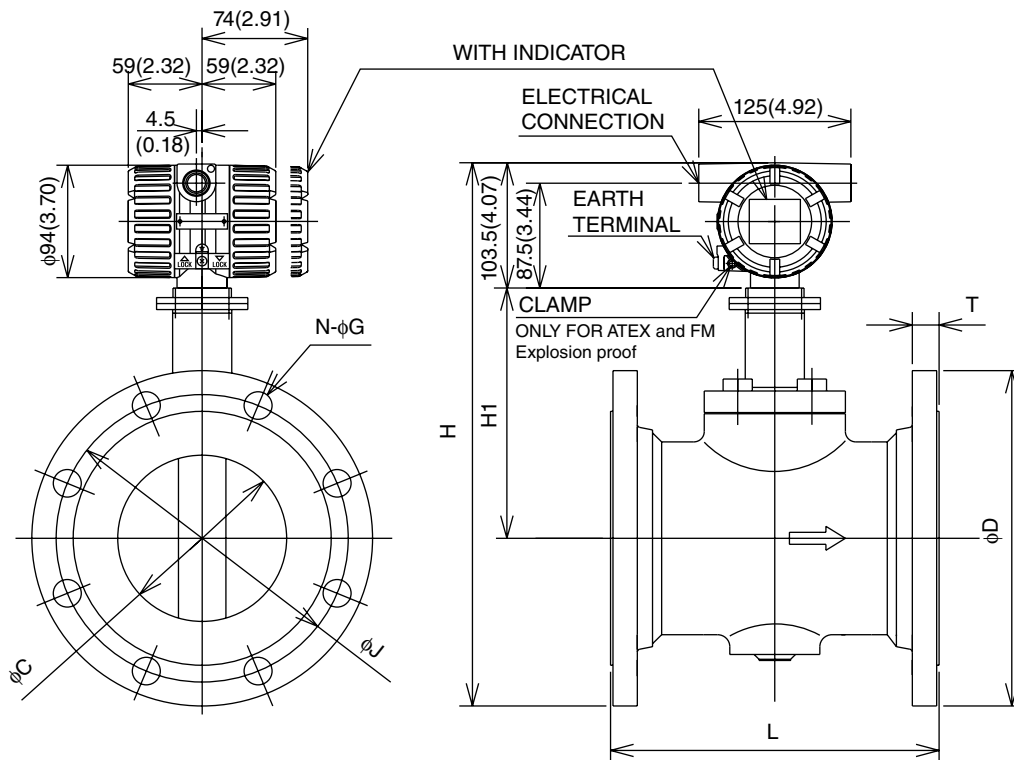
TYPE	INTEGRAL/REMOTE																		
	DY040 (40mm, 1 1/2 in)									DY050 (50mm, 2 in)									
PROCESS CONNECTION	BA1	BA2	BA4	BA5	BD4	BD6	BD7	CA4	CA5	N/A	BA1	BA2	BA4	BA5	BD4	BD6	BD7	CA4	CA5
L	150	200	200	150	180	185	200	200	200	N/A	170	230	230	170	195	195	195	205	230
C	39.7 (1.56)																		
D	127	155.4	155.4	177.8	150	170	170	155.4	177.8	152.4	165.1	165.1	215.9	165	180	195	195	165.1	215.9
H	303	317	317	339.5	314.5	324.5	325	317	328.5	337.5	344	344	369.5	344	351.5	359	359	344	369.5
H1	136 (5.35)																		
T	17.5	20.6	28.8	38.2	18	26	28	28.8	38.2	19.1	22.4	31.8	44.5	20	26	28	30	33.3	46
J	38.6	114.3	114.3	124	110	125	125	114.3	124	120.7	127	127	165.1	125	135	145	145	127	165.1
N	4 (0.16)																		
G	15.7	22.4	22.4	28.8	18	22	22	22.4	28.8	19	19	19	25.4	18	22	26	26	19	25.4
WEIGHT	kg	8.1	9.3	11.3	16.2	8.8	12.7	12.7	11.7	16.3	11.7	13.2	14.8	26.5	11.3	14.3	15.2	15.8	26.9
	lb	17.86	20.51	24.92	35.72	19.40	28.00	28.00	25.80	35.94	25.80	29.11	32.63	58.43	24.92	31.52	33.50	33.50	59.31

TYPE	INTEGRAL/REMOTE																						
	DY080 (80mm, 3 in)									DY100 (100mm, 4 in)													
PROCESS CONNECTION	BA1	BA2	BA4	BA5	BD2	BD4	BD5	BD6	BD7	CA4	CA5	BA1	BA2	BA4	BA5	BD2	BD4	BD5	BD6	BD7	CA4	CA5	
L	200	245	245	200	230	235	250	230	235	250	250	220	240	280	280	220	240	280	280	260	270	285	
C	71 (2.80)																						
D	190.5	209.6	209.6	241.3	200	200	215	230	230	209.6	241.3	228.6	254	273	292.1	220	235	250	265	265	273	292.1	
H	374	383.5	383.5	399	378.5	378.5	386	393.5	394	383.5	399	409	420.5	430	439.5	403.5	411	418.5	426	426	430	439.5	
H1	175 (6.89)																						
T	23.9	28.4	38.2	44.5	20	24	28	32	36	39.7	46	23.9	31.8	44.5	50.9	20	24	30	36	40	46	52.4	
J	152.4	168.2	168	190.5	160	160	170	180	180	170	180	190.5	200.2	216	235	180	190	200	210	210	216	235	
N	4 (0.16)																						
G	19	22.4	22.4	25.4	18	18	22	26	26	22.4	25.4	19	22.4	25.4	31.8	18	22	26	30	30	25.4	31.8	
WEIGHT	kg	20	23.8	25.4	35.7	19.4	20	24.1	27	26	27.1	36.3	27.4	35.9	50.8	55.9	23.2	27.4	33	39.7	39.7	52.8	56.6
	lb	44.10	52.48	56.01	78.72	42.78	44.10	53.14	59.53	57.33	59.76	80.04	60.42	79.16	112.01	123.26	51.16	60.42	72.74	87.51	87.51	116.42	124.80

(Note 1) Integral weight is the same as Remote
(Note 2) In the case of with Indicator, add 0.2 kg
(Note 3) The flow direction is opposite (right to left when facing onto indicator) in case of code/ /RC.

Flange type (DY150 up to DY200)

Unit: mm
(approx. in)



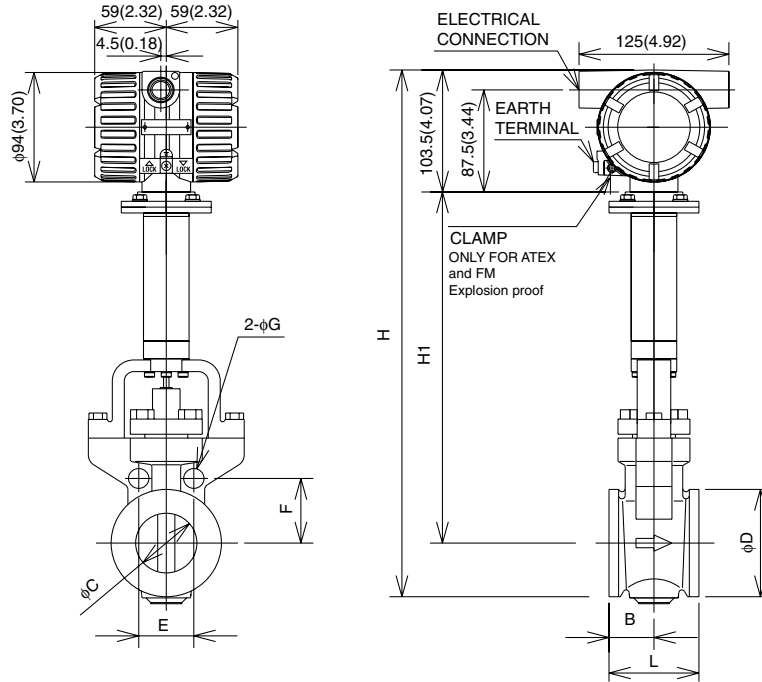
TYPE	INTEGRAL/REMOTE																
MODEL CODE	DY150								DY200								
PROCESS CONNECTION	BA1	BA2	BA4		BD2	BD4	BD5	BD6	CA4	BA1	BA2		BD1	BD2	BD3	BD4	
L	270 (10.63)	310 (12.21)			270 (10.63)			325 (12.80)		310 (12.20)			310 (12.20)				
C	138.8 (5.46)								185.6 (7.31)								
D	279.4 (11.00)	317.5 (12.50)	356 (14.02)		285 (11.22)	300 (11.81)	345 (13.53)	355 (13.93)	356 (14.02)	342.9 (13.50)	381 (15.00)		340 (13.39)	340 (13.39)	360 (14.17)	375 (14.76)	
H	Shedder Bar Material: L, E, X	452 (17.80)	471 (18.54)	491 (19.33)	455 (17.91)	463 (18.23)	485 (19.02)	490 (19.22)	491 (19.33)	516 (20.31)	535 (21.06)		515 (20.28)	515 (20.28)	525 (20.67)	532 (20.94)	
	Shedder Bar Material: B	459 (18.67)	476 (18.82)	498 (19.61)	462 (18.19)	470 (18.50)			498 (19.61)	523 (20.59)	542 (21.34)		522 (20.55)	522 (20.55)	532 (20.94)	539 (21.22)	
H1	Shedder Bar Material: L, E, X	209 (8.23)								241 (9.49)							
	Shedder Bar Material: B	216 (8.50)								248 (9.76)							
T	25.4 (1.00)	36.6 (1.44)	54.4 (2.14)		22 (0.87)	28 (1.10)	36 (1.41)	44 (1.72)	55.7 (2.19)	28.4 (1.12)	41.1 (1.62)		24 (0.95)	24 (0.95)	30 (1.18)	34 (1.34)	
J	241.3 (9.50)	269.7 (10.62)	292 (11.50)		240 (9.45)	250 (9.84)	280 (10.98)	290 (11.38)	292 (11.50)	298.5 (11.75)	330.2 (13.00)		295 (11.61)	295 (11.61)	310 (12.20)	320 (12.60)	
N	8	12	12		8	8	8	12	12	8	12		8	12	12	12	
G	22.4 (0.88)	22.4 (0.88)	28.4 (1.12)		22 (0.87)	26 (1.02)	33 (1.19)	33 (1.19)	28.4 (1.12)	25 (0.98)	25.4 (1.00)		22 (0.87)	22 (0.87)	26 (1.02)	30 (1.18)	
WEIGHT kg (lb)	36.4 (80.26)	54.4 (119.95)	84.4 (186.10)		33.4 (73.65)	42.9 (94.59)	58.1 (128.07)	76.4 (168.61)	90 (198.45)	55.4 (122.16)	80.4 (177.28)		46.3 (102.09)	46.3 (102.09)	53.6 (118.19)	55.9 (123.26)	

(Note 1) Integral weight is the same as Remote.
 (Note 2) In case of with Indicator, add 0.2kg.
 (Note 3) The flow direction is opposite (right to left when facing onto indicator) in case of code/CRC.

High Process Temperature Version (/HT): DY025-/HT up to DY100-/HT

Wafer type

Unit: mm
(approx. in)



TYPE	Only for REMOTE						
CODE	DY015 (15mm, 1/2 in) Only for /LT						
PROCESS CONNECTION	AA1	AA2	AA4	AD4	N/A	N/A	N/A
L	70 (2.76)						
B	35 (1.38)						
C	14.6 (0.57)						
D	35.1 (1.38)						
H	391 (15.39)						
H1	270 (10.63)						
E	42.7 (1.68)	47.1 (1.85)	47.1 (1.85)	46 (1.81)			
F	21.4 (0.84)	23.5 (0.93)	23.5 (0.93)	23 (0.91)			
G	14 (0.55)	14 (0.55)	14 (0.55)	13 (0.51)			
WEIGHT kg	3.2 (7.06lb)						

TYPE	Only for REMOTE																					
CODE	DY025 (25mm, 1 in) /LT, /HT							DY040 (40mm, 1 1/2 in) /LT, /HT							DY050 (50mm, 2 in) /LT, /HT							
PROCESS CONNECTION	AA1	AA2	AA4	AD4	N/A	N/A	N/A	AA1	AA2	AA4	AD4	N/A	N/A	N/A	AA1	AA2	AA4	AD4	N/A	N/A	N/A	
L	70 (2.76)							70 (2.76)							75 (2.95)							
B	35 (1.38)							35 (1.38)							37.5 (1.48)							
C	25.7 (1.01)							39.7 (1.56)							51.1 (2.01)							
D	50.8 (2.00)							73 (2.87)							92 (3.62)							
H	401 (15.79)							419 (16.50)							450.5 (17.74)							
H1	272 (10.71)							279 (10.98)							301 (11.85)							
E	56 (2.20)	62.9 (2.48)	62.9 (2.48)	60.1 (2.37)				69.7 (2.74)	80.8 (3.18)	80.8 (3.18)	77.8 (3.06)				(Note 1)	48.6 (1.91)	48.6 (1.91)	(Note 1)				
F	28 (1.10)	31.4 (1.24)	31.4 (1.24)	30.1 (1.19)				34.8 (1.37)	40.4 (1.59)	40.4 (1.59)	38.9 (1.53)				(Note 1)	58.7 (2.31)	58.7 (2.31)	(Note 1)				
G	14 (0.55)	17 (0.67)	17 (0.67)	13 (0.51)				14 (0.55)	20 (0.79)	20 (0.79)	17 (0.67)				(Note 1)	17 (0.67)	17 (0.67)	(Note 1)				
WEIGHT kg	4.1 (9.04lb)							4.7 (10.36lb)							6.4 (14.11lb)							

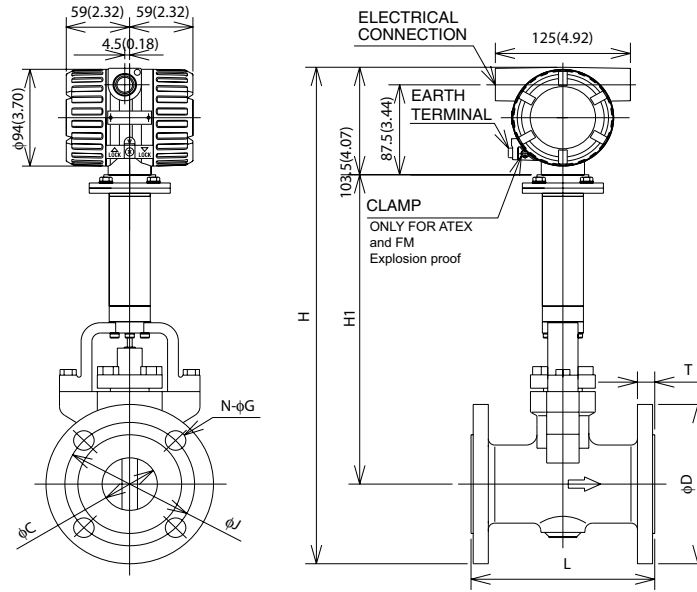
TYPE	Only for REMOTE														
CODE	DY080 (80mm, 3 in) /LT, /HT							DY100 (100mm, 4 in) /LT, /HT							
PROCESS CONNECTION	AA1	AA2	AA4	AD4	N/A	N/A	N/A	AA1	AA2	AA4	AD2	AD4	N/A	N/A	N/A
L	100 (3.94)							120 (4.72)							
B	40 (1.57)							50 (1.97)							
C	71 (2.80)							93.8 (3.69)							
D	127 (5.00)							157.2 (6.19)							
H	485 (19.09)							515 (20.28)							
H1	318 (12.52)							333 (13.11)							
E	(Note 1)	64.4 (2.54)	64.4 (2.54)	61.2 (2.41)				72.9 (2.87)	76.6 (3.02)	82.6 (3.25)	68.9 (2.71)	72.7 (2.86)			
F	(Note 1)	77.7 (3.06)	77.7 (3.06)	73.9 (2.91)				88 (3.46)	92.5 (3.64)	93.7 (3.93)	83.1 (3.27)	87.8 (3.46)			
G	(Note 1)	20 (0.79)	20 (0.79)	17 (0.67)				17 (0.67)	20 (0.79)	23 (0.91)	17 (0.67)	21 (0.83)			
WEIGHT kg	9.8 (21.61lb)							13.2 (29.11lb)							

(Note 1) The hole is not provided.
(Note 2) The flow direction is opposite (right to left when facing onto indicator) in case of code / CRC.

High Process Temperature Version (/HT): DY025-/HT up to DY100-/HT

Flange type

Unit: mm
(approx. in)



TYPE	Only for REMOTE																			
	DY015 (15mm, 1/2 in) Only for /LT										DY025 (25mm, 2 in) /LT, /HT									
PROCESS CONNECTION	BA1	BA2	BA4	BA5	BD4	BD6	BD7	CA4	CA5	N/A	BA1	BA2	BA4	BA5	BD4	BD6	BD7	CA4	CA5	N/A
L	130 (5.12)										150 (5.91)									
C	14.6 (0.57)										25.7 (1.01)									
D	88.9 (3.50)	95.3 (3.75)	95.3 (3.75)	120.7 (4.75)	130 (5.12)	130 (5.12)	105 (4.12)	140 (5.51)	120.7 (4.75)		108 (4.25)	124 (4.88)	124 (4.88)	149.4 (5.88)	115 (4.53)	140 (5.49)	140 (5.49)	124 (4.88)	149.4 (5.88)	
H	418 (16.46)	421 (16.57)	421 (16.57)	434 (17.09)	421 (16.57)	426 (16.71)	426 (16.71)	434 (17.09)	434 (17.09)		430 (16.93)	438 (17.24)	438 (17.24)	450 (17.72)	433 (17.09)	446 (17.56)	446 (17.56)	438 (17.24)	450 (17.72)	
H1	270 (10.63)										272 (10.71)									
T	11.2 (0.44)	14.2 (0.56)	21 (0.83)	28.8 (1.13)	16 (0.63)	20 (0.78)	20 (0.78)	19.9 (0.78)	28.8 (1.13)		14.2 (0.56)	17.5 (0.69)	24 (0.94)	34.9 (1.37)	18 (0.71)	24 (0.94)	24 (0.94)	24 (0.94)	34.9 (1.37)	
J	60.5 (2.38)	66.5 (2.62)	66.5 (2.62)	82.6 (3.25)	65 (2.56)	75 (2.94)	75 (2.94)	82.6 (3.25)	82.6 (3.25)		79.2 (3.12)	89 (3.50)	89 (3.50)	101.6 (4.00)	85 (3.35)	100 (3.92)	100 (3.92)	89 (3.50)	101.6 (4.00)	
N	4 (0.16)										4 (0.16)									
G	15.7 (0.62)	15.7 (0.62)	15.7 (0.62)	22.4 (0.88)	14 (0.55)	14 (0.55)	15.7 (0.62)	22.4 (0.88)	22.4 (0.88)		15.7 (0.62)	19 (0.75)	19 (0.75)	25.4 (1.00)	14 (0.55)	18 (0.71)	18 (0.71)	19 (0.75)	25.4 (1.00)	
WEIGHT kg	4.5	4.7	5.0	7.1	4.6	5.8	5.8	4.9	7.2		7.0	7.6	8.1	11.5	7.3	10.0	10.0	8.3	11.8	
lb	9.92	10.36	11.03	15.66	10.14	12.79	12.79	10.80	15.88		15.44	16.76	17.86	25.36	16.10	22.05	22.05	18.30	26.02	

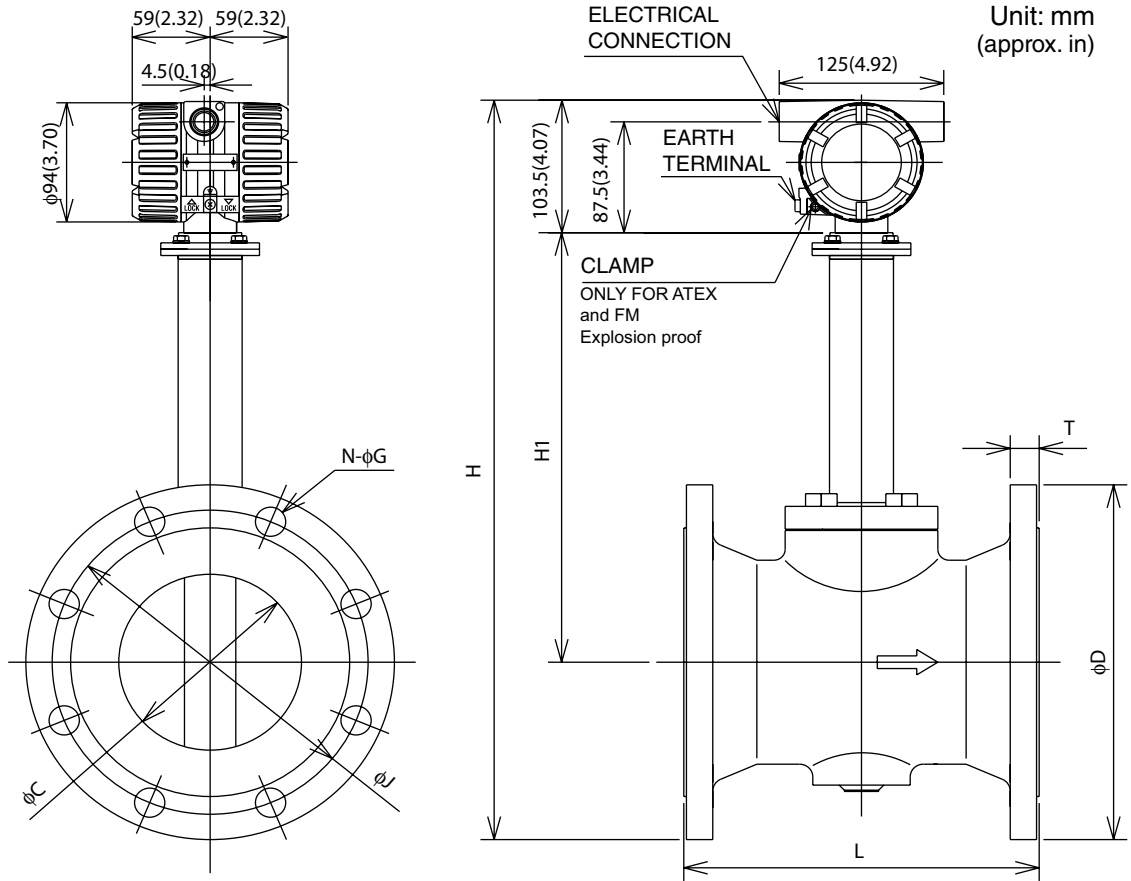
TYPE	Only for REMOTE																			
	DY040 (40mm, 1 1/2 in) /LT, /HT										DY050 (50mm, 2 in) /LT, /HT									
PROCESS CONNECTION	BA1	BA2	BA4	BA5	BD4	BD6	BD7	CA4	CA5	N/A	BA1	BA2	BA4	BA5	BD4	BD6	BD7	CA4	CA5	N/A
L	150 (5.91)										170 (6.69)									
C	39.7 (1.56)										51.1 (2.01)									
D	127 (5.00)	155.4 (6.12)	155.4 (6.12)	177.8 (7.00)	150 (5.91)	170 (6.69)	170 (6.69)	155.4 (6.12)	177.8 (7.00)		152.4 (6.00)	165.1 (6.50)	165.1 (6.50)	215.9 (8.50)	165 (6.50)	180 (7.06)	195 (7.65)	165.1 (6.50)	215.9 (8.50)	
H	446 (17.56)	460 (18.11)	460 (18.11)	472 (18.58)	458 (18.03)	468 (18.36)	468 (18.36)	472 (18.58)	472 (18.58)		481 (18.94)	487 (19.17)	487 (19.17)	513 (20.20)	487 (19.17)	495 (19.42)	502 (19.69)	487 (19.17)	513 (20.20)	
H1	279 (10.98)										301 (11.85)									
T	17.5 (0.69)	20.6 (0.81)	28.8 (1.13)	38.2 (1.50)	18 (0.71)	26 (1.02)	26 (1.02)	28.8 (1.13)	38.2 (1.50)		19.1 (0.75)	24.4 (0.98)	31.8 (1.25)	44.5 (1.75)	26 (1.02)	28 (1.10)	28 (1.10)	28 (1.10)	46 (1.81)	
J	98.6 (3.88)	114.3 (4.50)	114.3 (4.50)	124 (4.88)	110 (4.33)	125 (4.90)	124 (4.90)	114.3 (4.50)	124 (4.88)		120.7 (4.75)	127 (5.00)	127 (5.00)	165.1 (6.50)	125 (4.92)	135 (5.30)	145 (5.69)	127 (5.00)	165.1 (6.50)	
N	4 (0.16)										4 (0.16)									
G	15.7 (0.62)	22.4 (0.88)	22.4 (0.88)	28.4 (1.12)	18 (0.71)	22 (0.86)	22 (0.86)	22.4 (0.88)	28.4 (1.12)		19 (0.75)	19 (0.75)	19 (0.75)	25.4 (1.00)	18 (0.71)	22 (0.86)	22 (0.86)	18 (0.71)	25.4 (1.00)	
WEIGHT kg	8.5	9.7	11.7	16.6	9.2	13.1	13.1	12.1	16.7		12.1	13.6	15.2	26.9	11.7	14.7	15.6	15.6	16.2	27.3
lb	18.74	21.39	25.80	36.60	20.29	28.88	28.88	26.68	36.82		26.68	29.99	33.52	59.32	25.80	32.41	34.40	34.40	35.72	60.20

TYPE	Only for REMOTE																					
	DY080 (80mm, 3 in) /LT, /HT											DY100 (100mm, 4 in) /LT, /HT										
PROCESS CONNECTION	BA1	BA2	BA4	BA5	BD2	BD4	BD5	BD6	BD7	CA4	CA5	BA1	BA2	BA4	BA5	BD2	BD4	BD5	BD6	BD7	CA4	CA5
L	200 (7.87)											220 (8.66)										
C	71 (2.80)											93.8 (3.69)										
D	190.5 (7.50)	209.6 (8.25)	209.6 (8.25)	241.3 (9.50)	200 (7.87)	200 (7.87)	215 (8.53)	230 (9.02)	230 (9.02)	209.6 (8.25)	241.3 (9.50)	228.6 (9.00)	254 (10.00)	273 (10.75)	292.1 (11.50)	220 (8.66)	235 (9.25)	250 (9.81)	265 (10.40)	265 (10.40)	273 (10.75)	292.1 (11.50)
H	517 (20.35)	527 (20.75)	527 (20.75)	542 (21.34)	522 (20.55)	522 (20.55)	529 (20.75)	537 (21.07)	537 (21.07)	542 (21.34)	542 (21.34)	552 (21.73)	564 (22.20)	573 (22.56)	583 (22.95)	547 (21.54)	554 (21.81)	562 (22.04)	569 (22.32)	569 (22.32)	573 (22.56)	583 (22.95)
H1	318 (12.52)											333 (13.11)										
T	23.9 (0.94)	28.4 (1.12)	38.2 (1.50)	44.5 (1.75)	20 (0.79)	21 (0.84)	28 (1.10)	32 (1.25)	36 (1.41)	38.2 (1.50)	46 (1.81)	23.9 (0.94)	31.8 (1.25)	44.5 (1.75)	50.9 (2.00)	20 (0.79)	24 (0.94)	30 (1.18)	30 (1.18)	40 (1.57)	46 (1.81)	52.4 (2.06)
J	152.4 (6.00)	168.2 (6.61)	168.2 (6.61)	190.5 (7.50)	160 (6.30)	160 (6.30)	180 (7.09)	180 (7.09)	180 (7.09)	160 (6.30)	180 (7.09)	190.5 (7.50)	200.2 (7.88)	216 (8.50)	235 (9.25)	180 (7.09)	190 (7.48)	200 (8.24)	210 (8.24)	216 (8.50)	235 (9.25)	235 (9.25)
N	8 (0.31)											8 (0.31)										
G	19 (0.75)	22.4 (0.88)	22.4 (0.88)	25.4 (1.00)	18 (0.71)	22 (0.86)	22 (0.86)	22.4 (0.88)	25.4 (1.00)	25.4 (1.00)	25.4 (1.00)	19 (0.75)	22.4 (0.88)	25.4 (1.00)	31.8 (1.25)	18 (0.71)	22 (0.86)	26 (1.02)	30 (1.18)	30 (1.18)	25.4 (1.00)	31.8 (1.25)
WEIGHT kg	20.4	24.2	25.8	36.1	19.8	20.4	24.5	27.4	27.4	27.5	36.7	27.7	36.3	51.2	56.3	23.6	27.8	33.4	40.1	40.1	53.2	57.0
lb	44.98	53.36	56.89	79.60	43.66	44.98	54.02	60.41	60.41	80.92	80.92	61.30	80.04	112.90	124.14	52.04	61.30	73.64	88.42	88.42	117.31	125.69

(Note 1) The flow direction is opposite (right to left when facing onto indicator) in case of code /CRC.

High Process Temperature Version (/HT): DY150-/HT up to DY200-/HT

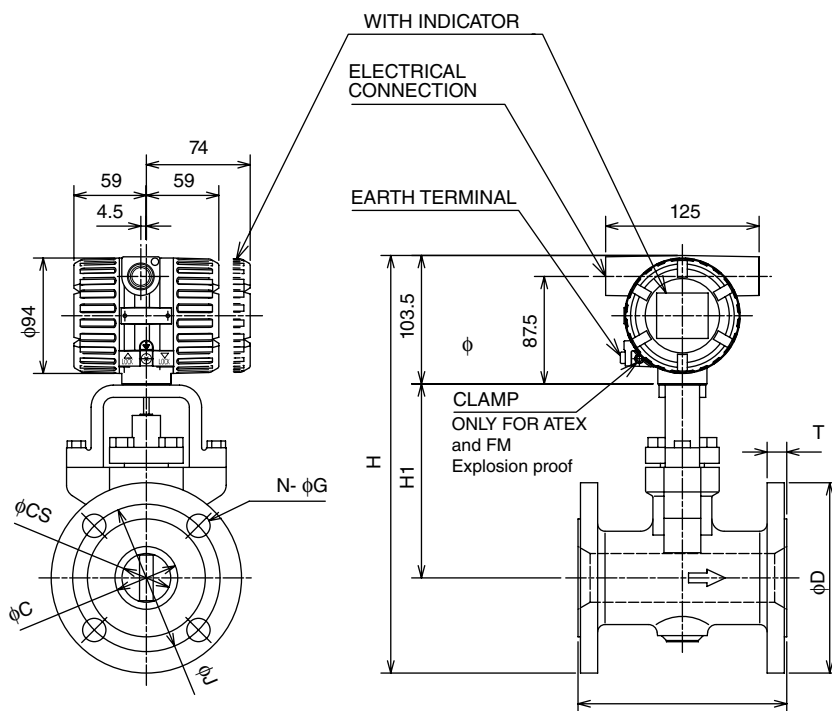
Flange type



TYPE	ONLY FOR REMOTE															
CODE	DY150 (150mm,6 in) / HT								DY200 (200mm,8 in) / HT							
PROCESS CONNECTION	BA1	BA2	BA4	BD2	BD4	BD5	BD6	CA4	BA1	BA2	BD1	BD2	BD3	BD4		
L	270 (10.63)	310 (12.20)		270 (10.63)				325 (12.80)	310 (12.20)				310 (12.20)			
C	138.8 (5.46)								185.6 (7.31)							
D	279.4 (11.00)	317.5 (12.50)	356 (14.02)	285 (11.22)	300 (11.81)	345 (13.37)	355 (13.76)	356 (14.02)	342.9 (13.50)	381 (15.00)	340 (13.39)	340 (13.39)	360 (14.17)	375 (14.76)		
H	582 (22.91)	601 (23.66)	621 (24.45)	585 (23.03)	593 (23.35)	615 (23.83)	620 (24.02)	621 (24.45)	646 (25.43)	665 (26.18)	645 (25.39)	645 (25.39)	655 (25.79)	662 (26.06)		
H1	339 (13.35)								371 (14.61)							
T	25.4 (1.00)	36.6 (1.44)	54.4 (2.14)	22 (0.87)	28 (1.10)	36 (1.39)	44 (1.71)	55.7 (2.19)	28.4 (1.12)	41.1 (1.62)	24 (0.95)	24 (0.95)	30 (1.18)	34 (1.34)		
J	241.3 (9.50)	269.7 (10.62)	292 (11.50)	240 (9.45)	250 (9.84)	280 (10.85)	290 (11.24)	292 (11.50)	298.5 (11.75)	330.2 (13.00)	295 (11.61)	295 (11.61)	310 (12.20)	320 (12.60)		
N	8 (0.31)	12 (0.47)	12 (0.47)	8 (0.31)	8 (0.31)	8 (0.31)	12 (0.47)	12 (0.47)	8 (0.31)	12 (0.47)	8 (0.31)	12 (0.47)	12 (0.47)	12 (0.47)		
G	22.4 (0.88)	22.4 (0.88)	28.4 (1.12)	22 (0.87)	26 (1.02)	33 (1.28)	33 (1.28)	28.4 (1.12)	22.4 (0.88)	25.4 (1.00)	22 (0.87)	22 (0.87)	26 (1.02)	30 (1.18)		
WEIGHT	kg	36.4	54.4	84.4	33.4	42.9	58.1	76.4	90	55.4	80.4	46.3	46.3	53.6	55.9	
	lb	80.26	119.95	186.10	73.65	94.59	128.10	168.45	198.45	122.16	177.28	102.09	102.09	118.19	123.26	

(Note 1) The flow direction is opposite (right to left when facing onto indicator) in case of code / CRC.

Reduced Bore Type (/R1): DY025-/R1 up to DY150-/R1
Flange type



Model Code	DY025 /R1			
Process Connection	BA1	BA2	BD4	N/A
L	150			
C	25.7			
CS	14.6			
D	108	124	115	
H	284.5	292.5	288	
H1	127			
T	14.2	17.5	18	
J	79.2	89	85	
N	4			
G	15.7	19	14	
Weight kq	5.5	7.0	6.0	

Model Code	DY040 /R1			
Process Connection	BA1	BA2	BD4	N/A
L	150			
C	39.7			
CS	25.7			
D	127	155.4	150	
H	296	310	307	
H1	129			
T	17.5	20.6	18	
J	98.6	114.3	110	
N	4			
G	15.7	22.4	18	
Weight kq	9.4	12.6	11.5	

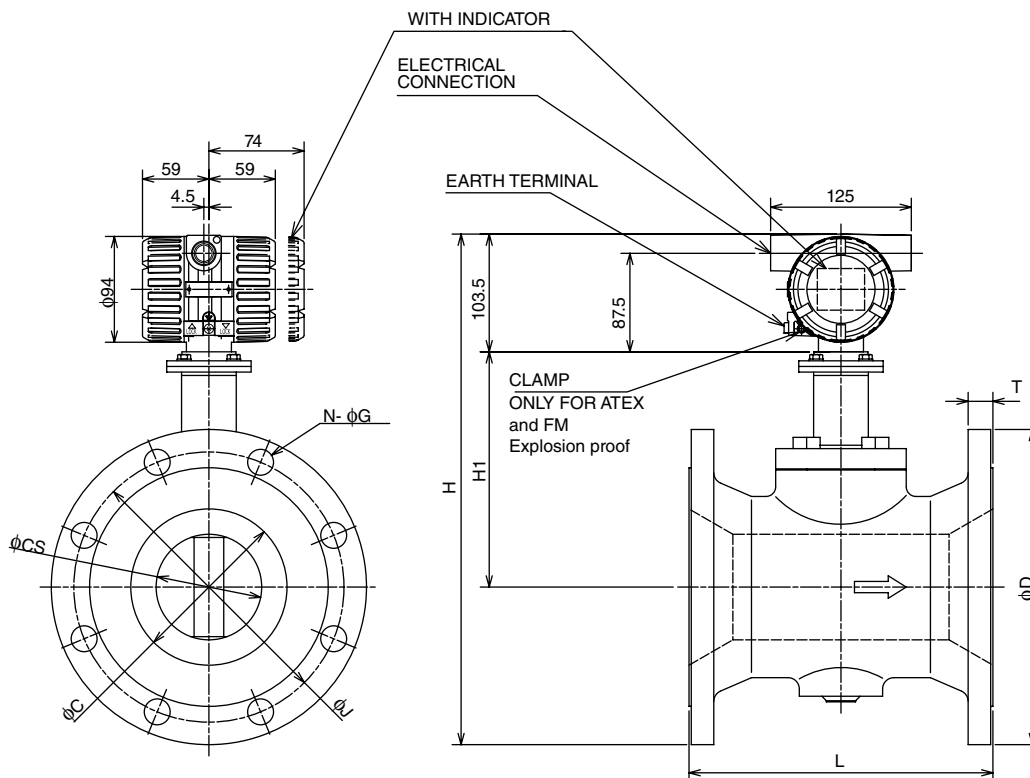
Model Code	DY050 /R1			
Process Connection	BA1	BA2	BD4	N/A
L	170			
C	51.1			
CS	39.7			
D	152.4	165.1	165	
H	315.5	322	322	
H1	136			
T	19.1	22.4	20	
J	120.7	127	125	
N	4	8	4	
G	19	19	18	
Weight kq	11.4	13.6	13.6	

Model Code	DY080 /R1			
Process Connection	BA1	BA2	BD2	BD4
L	200			
C	71			
CS	51.1			
D	190.5	209.6	200	200
H	357	366.5	268	361
H1	158			
T	23.9	28.4	20	24
J	152.4	168.2	160	160
N	4	8	8	8
G	19	22.4	18	18
Weight kq	21.9	26.9	23	23.5

Model Code	DY100 /R1			
Process Connection	BA1	BA2	BD2	BD4
L	220			
C	93.8			
CS	71			
D	228.6	254	220	235
H	393	405.5	388.5	396
H1	175			
T	23.9	31.8	20	24
J	190.5	200.2	180	190
N	8			
G	19	22.4	18	22
Weight kq	30.6	41.0	29	44.5

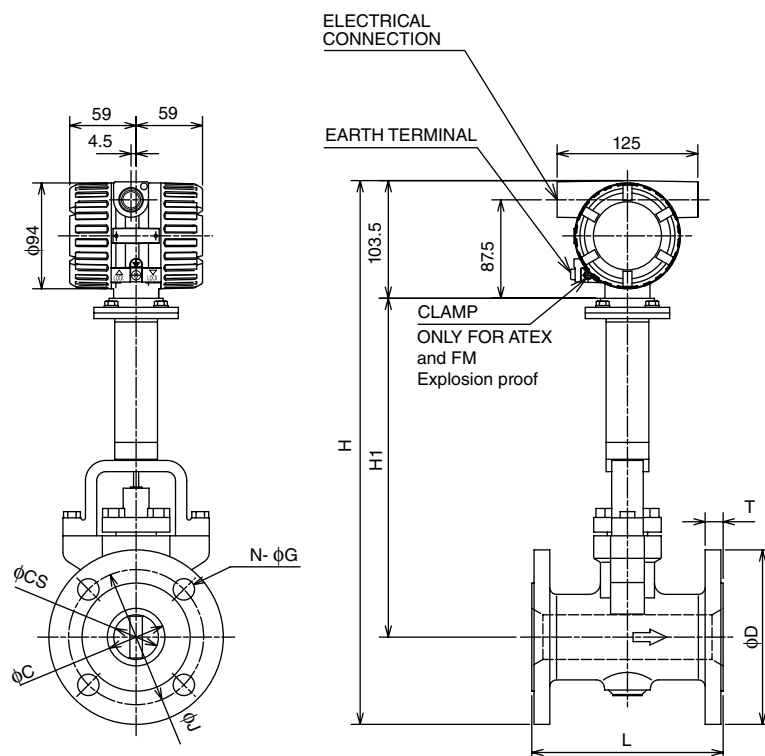
Model Code	DY150 /R1			
Process Connection	BA1	BA2	BD2	BD4
L	270			
C	138.8			
CS	93.8			
D	279.4	317.5	285	300
H	433	452	436	442.5
H1	190			
T	25.4	36.6	22	28
J	241.3	269.7	240	250
N	8	12	8	8
G	22.4	22.4	22	26
Weight kq	49.4	71.7	48	58

Reduced Bore Type (/R1): DY200-/R1
Flange type



Model Code	DY200 /R1					
Process Connection	BA1	BA2	BD1	BD2	BD3	BD4
L	310					
C	185.6					
CS	138.8					
D	342.9	381	340	340	360	375
H	484	503	482	482	492.5	500
H1	209					
T	28.4	41.1	24	24	30	34
J	298.5	330.2	295	295	310	320
N	8	12	8	12	12	12
G	22.4	25.4	22	22	26	30
Weight kg	70.7	102.9	67	67	74	90

**Reduced Bore Type High Process Temperature Version (/R1/HT): DY040-/HT/R1 up to DY150-/R1/HT
Flange type**



Model Code	DY040 /R1/HT			
Process Connection	BA1	BA2	BD4	N/A
L	150			
C	39.7			
CS	25.7			
D	127	155.4	150	
H	439	453	450	
H1	272			
T	17.5	20.6	18	
J	98.6	114.3	110	
N	4			
G	15.7	22.4	18	
Weight kg	9.8	13.0	10.0	

Model Code	DY050 /R1/HT			
Process Connection	BA1	BA2	BD4	N/A
L	170			
C	51.1			
CS	39.7			
D	152.4	165.1	165	
H	458.5	465	405	
H1	279			
T	19.1	22.4	20	
J	120.7	127	125	
N	4	8	4	
G	19	19	18	
Weight kg	11.8	14.0	14.0	

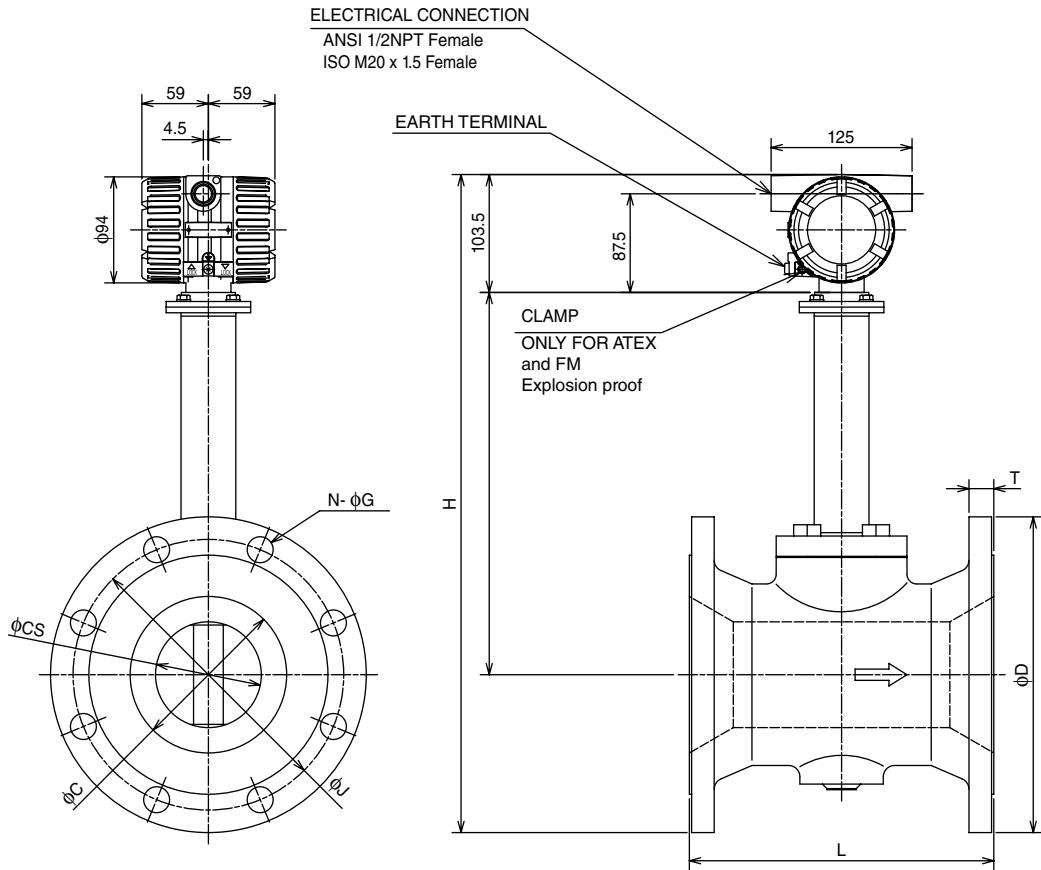
Model Code	DY080 /R1/HT			
Process Connection	BA1	BA2	BD2	BD4
L	200			
C	71			
CS	51.1			
D	190.5	209.6	200	200
H	500	509.5	504	504
H1	301			
T	23.9	28.4	20	24
J	152.4	168.2	160	160
N	4	8	8	8
G	19	22.4	18	18
Weight kg	22.3	27.3	22.0	24.0

Model Code	DY100 /R1/HT			
Process Connection	BA1	BA2	BD2	BD4
L	220			
C	93.8			
CS	71			
D	228.6	254	220	235
H	536	548.5	531	539
H1	318			
T	23.9	31.8	20	24
J	190.5	200.2	180	190
N	8			
G	19	22.4	18	22
Weight kg	31.0	41.4	31.0	40.0

Model Code	DY150 /R1/HT			
Process Connection	BA1	BA2	BD2	BD4
L	270			
C	138.8			
CS	93.8			
D	279.4	317.5	285	300
H	576	595.5	579	586.5
H1	333			
T	25.4	36.6	22	28
J	241.3	269.7	240	250
N	8	12	8	8
G	22.4	22.4	22	26
Weight kg	49.4	71.7	49.0	70.0

Reduced Bore Type High Process Temperature Version (/R1/HT): DY200-/R1/HT

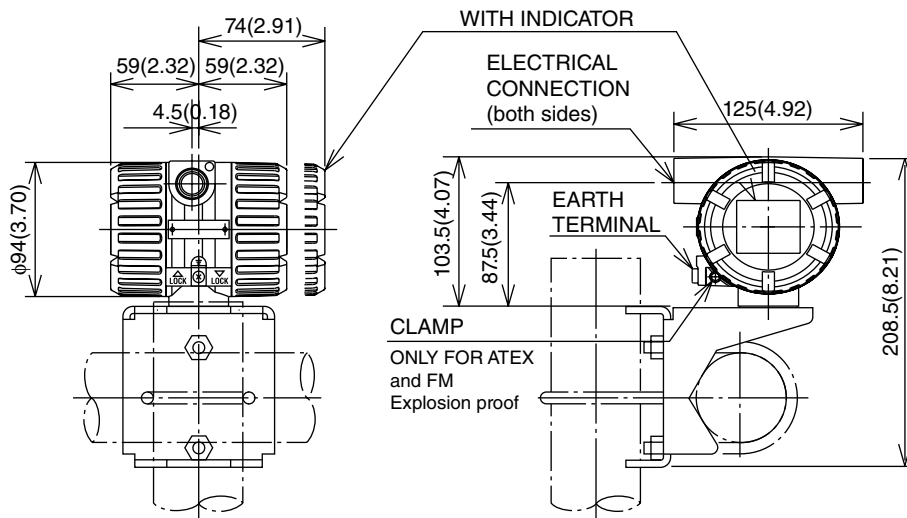
Flange type



Model Code	DY200 /R1/HT					
Process Connection	BA1	BA2	BD1	BD2	BD3	BD4
L	310					
C	185.6					
CS	138.8					
D	342.9	381	340	340	360	375
H	614	633	612	612	622.5	630
H1	339					
T	28.4	41.1	24	24	30	34
J	298.5	330.2	295	295	310	320
N	8	12	8	12	12	12
G	22.4	25.4	22	22	26	30
Weight kg	70.7	102.9	70	72	80	90

Remote Type Converter (DYA)

Unit: mm
(approx. in)



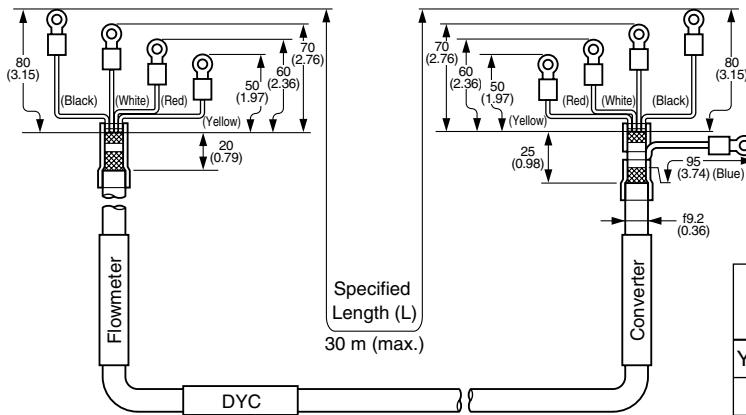
Weight: 1.9 kg (4.19 lb)

Note: For flowmeters with indicator, add 0.2 kg (0.44 lb)

Note: The standard material for the bracket for the remote converter DYA is painted carbon steel. Material is subject to availability and might change to stainless steel at time of delivery with

Signal Cable for Remote Type (DYC)

Unit: mm
(approx. in)



Cable Color and Terminal

Color	Terminal	
	Flow meter	Converter
Yellow ^(*)	T	T
Red	A	A
White	B	B
Black	\perp	C
Blue		\perp

(*) Only for /MV

ORDERING INSTRUCTIONS

Specify the following when ordering :

1. Model and suffix codes.
2. Option code /MV:

Select one of the six items below from [MULTI-VARIABLE FUNCTION].

 - 1) Temperature monitoring/output
 - 2) Saturated steam mass flowrate
 - 3) Super-heated steam mass flowrate
 - 4) Gas volume flow rate
 - 5) Liquid mass flow rate
 - 6) Not use function
3. Flow conditions
 - a) Output Signal
 - b) Communication
 - c) Nominal Size (size of model code)
 - d) Kind of Fluid
 - e) Fluid Name
 - f) Span, normal flow and minimum flow rates
 - g) Maximum and normal operating temperatures
 - h) Maximum and normal operating pressures
 - i) Density at normal conditions
 - j) Viscosity at normal conditions
 - k) Deviation factor
 - l) Totalized value rate
- m) Pulse rate



NOTE

digitalYEFWLO Sizing Program is necessary to make a sizing data.

4. Tag Number



NOTE

If a tag number is specified upon ordering, the parameter "Tag No." is set up before shipment; Up to 16 digits are programmable. The number programmed is then identical to the tag number on the data plate. If additionally to the tag number a software tag number was specified upon ordering the software tag number is the number that will be programmed in parameter "Tag No.": The possible length for programming a software tag number depends on the communication code.

DY[]-[]-D = BRAIN: up to 16 digits

DY[]-[]-J = HART 5 : up to 8 digits

DY[]-[]-J = HART 7 : up to 32 digits

DY[]-[]-F = Foundation Fieldbus: up to 32 digits

If value was not set to your requirements, it will be necessary for the appropriate value to be set by the user. Refer to GS 01F06F00-01E for Fieldbus communication type.

==== RELATED INSTRUMENTS =====

SDBT Distributor See GS 1B4T1-E
See GS 1B4T2-E

==== RELATED MATERIAL =====

Model DY Vortex Flowmeter TI 1F6A00-01E
Model DY Foundation Fieldbus GS 01F06F01-01E

GS 01R06A00-01E-E 10th edition is based on
GS 01F06A00-01E 23th edition.

YOKOGAWA

YOKOGAWA ELECTRIC CORPORATION

Headquarters

2-9-32, Nakacho, Musashino-shi, Tokyo, 180-8750 JAPAN
Phone : 81-422-52-5555

Branch Sales Offices

Osaka, Nagoya, Hiroshima, Kurashiki, Fukuoka, Kitakyusyu

YOKOGAWA CORPORATION OF AMERICA

Head Office

12530 West Airport Blvd, Sugar Land, Texas 77478, USA
Phone : 1-281-340-3800 Fax : 1-281-340-3838

Georgia Office

2 Dart Road, Newnan, Georgia 30265, USA
Phone : 1-800-888-6400/ 1-770-253-7000 Fax : 1-770-254-0928

YOKOGAWA AMERICA DO SUL LTDA.

Praca Acapulco, 31 - Santo Amaro, São Paulo/SP, BRAZIL, CEP-04675-190
Phone : 55-11-5681-2400 Fax : 55-11-5681-4434

YOKOGAWA EUROPE B. V.

Euroweg 2, 3825 HD Amersfoort, THE NETHERLANDS
Phone : 31-88-4641000 Fax : 31-88-4641111

YOKOGAWA ELECTRIC CIS LTD.

Grokholskiy per 13 Building 2, 4th Floor 129090, Moscow, RUSSIA
Phone : 7-495-737-7868 Fax : 7-495-737-7869

YOKOGAWA CHINA CO., LTD.

3F Tower D Cartelo Crocodile Building, No.568 West Tianshan Road,
Shanghai 200335, CHINA
Phone : 86-21-62396262 Fax : 86-21-62387866

YOKOGAWA ELECTRIC KOREA CO., LTD.

(Yokogawa B/D, Yangpyeong-dong 4-Ga), 21, Seonyu-ro 45-gil, Yeongdeungpo-gu,
Seoul, 150-866, KOREA
Phone : 82-2-2628-6000 Fax : 82-2-2628-6400

YOKOGAWA ENGINEERING ASIA PTE. LTD.

5 Bedok South Road, Singapore 469270, SINGAPORE
Phone : 65-6241-9933 Fax : 65-6241-2606

YOKOGAWA INDIA LTD.

Plot No.96, Electronic City Complex, Hosur Road, Bangalore - 560 100, INDIA
Phone : 91-80-4158-6000 Fax : 91-80-2852-1442

YOKOGAWA AUSTRALIA PTY. LTD.

Tower A, 112-118 Talavera Road, Macquarie Park NSW 2113, AUSTRALIA
Phone : 61-2-8870-1100 Fax : 61-2-8870-1111

YOKOGAWA MIDDLE EAST & AFRICA B.S.C.(C)

P.O. Box 10070, Manama, Building 577, Road 2516, Busaiteen 225, Muharraq,
Kingdom of SAUDI ARABIA
Phone : 973-17358100 Fax : 973-17336100

Apr. '15